



REPUBLIC OF THE PHILIPPINES
DEPARTMENT OF BUDGET AND MANAGEMENT
General Solano Street, San Miguel, Manila

REQUEST FOR QUOTATION
No. 23-059A

The **Department of Budget and Management (DBM)** through its **Administrative Service**, intends to procure "**Supply, Delivery, and Installation of Urinal Units and Accessories at DBM Central Office**" for FY 2023 in accordance with **Section 53.9** (Negotiated Procurement – Small Value Procurement) of the 2016 Revised Implementing Rules and Regulations of Republic Act No. 9184.

Please quote your **best offer** for the item/s described herein, **subject to the attached Annexes A and B (Terms and Conditions)**, provided as part of this Request for Quotation (RFQ). Submit your quotation duly signed by your authorized representative **not later than September 14, 2023, 2:00 p.m.** at the Administrative Service – Procurement Management Division, Ground Floor, DBM Bldg. III, General Solano St., San Miguel, Manila. Quotations may also be submitted through the email address indicated below.

A copy of your 2023 **Business/Mayor's Permit** and **PhilGEPS Registration Number** is also required to be submitted along with your signed quotation/proposal. A **valid and updated** PhilGEPS Registration Certificate (Platinum Membership) (**all pages**) may be submitted in lieu of the Mayor's/Business Permit.

The Supplier/Service Provider with the Single/Lowest Calculated Quotation shall submit its **Omnibus Sworn Statement (GPPB-prescribed forms), Income/ Business Tax Return¹ (for ABC's above Php 500k)** within a non-extendible period of five (5) calendar days from receipt of the notice from the Administrative Service that it submitted the Single/Lowest Calculated Quotation.²

For any clarification, you may contact us at telephone no. **(02) 8657-3300 local 3115** or email address at **kcantoria@dbm.gov.ph**.

AARON ALBERTO A. ESCALONA
Chief Administrative Officer

¹Manually filed tax returns or filed through the EFPS

²Failure to submit the required documents on time, or a finding against the veracity thereof, shall disqualify the supplier/service provider for award. In case the notice for the submission of post-qualification documents is sent via the bidder's email, it shall be considered as received by the bidder on the date and time the email was sent, whether or not the bidder acknowledged the said email. It shall be the bidder's responsibility to check its/his/her email for the purpose.

Date: _____

Name of Company: _____

Address: _____

Name of Store/Shop: _____

Address: _____

TIN: _____

PhilGEPS Registration Number: _____

INSTRUCTIONS:

- (1) Accomplish this Request for Quotation (RFQ) correctly and accurately.
- (2) The use of this RFQ is highly encouraged to minimize errors or omissions of the mandatory provisions.

If a different form is used other than the RFQ, the quotation shall contain all the mandatory provisions, including manifestation on the agreement with the Terms and Conditions below.

In case a prospective supplier or service provider submits a filled-out RFQ with a supporting document (i.e., price quotation in a different format), both documents shall be considered unless there is any discrepancy. In this case, provisions in the RFQ shall prevail.

- (3) All technical specifications are mandatory. Failure to comply with any of the mandatory requirements will disqualify your quotation.
- (4) Failure to follow these instructions will disqualify your entire quotation.

Sir/Madam:

After having carefully read and accepted the Terms and Conditions in the Request for Quotation, hereunder is our quotation for the item/s as follows:

TECHNICAL SPECIFICATION

1. Please quote your **best offer** for the item/s below. Please do not leave any blank items. Indicate "0" if the item being offered is for free.
2. Bidders must state "Comply" or any equivalent term in the column "Bidder's Statement of Compliance" against each of the individual parameters of each Specification.
- 3.

Item	Description	Total Quantity	Bidder's Statement of Compliance	Unit Cost (Vat Inclusive)	Total Cost (Vat Inclusive)
	<p>Supply, Delivery, and Installation of Urinal Units and Accessories at DBM Central Office</p> <p><i>Please see attached Annex A for the Detailed Specifications of the project.</i></p>	1 Lot			

**The above quoted prices are inclusive of all costs and applicable taxes.*

SCHEDULE OF REQUIREMENTS

Bidder's Statement of Compliance

A.	<p>Supply, Delivery, and Installation of Urinal Units and Accessories at DBM Central Office</p> <p><i>See attached Section VI for the detailed Schedule of Requirements.</i></p>
----	---

FINANCIAL OFFER

Approved Budget for the Contract

Total Offered Quotation

Eight Hundred Thirty Thousand Pesos only

(Php 830,000.00)

In words: _____

In figures: _____

Payment Details:

<u>Payment Terms:</u>	Payment shall be made promptly, but in no case later than sixty (60) days, through Land Bank's LDDAP-ADA/Bank Transfer facility after submission of billing statement/invoice and upon fulfillment of other obligations as stipulated in the contract as well as upon inspection and acceptance of the goods by the end user, subject to other payment terms as prescribed in this RFQ.
Banking Institution	
Account Number	
Account Name	
Branch	

Signature over Printed Name

Position/Designation

Office Telephone No.

Fax/Mobile No.

Email address/es

TERMS AND CONDITIONS

1. Bidders shall provide correct and accurate information required in this form.
2. Price quotation/s must be valid for a period of *sixty (60) calendar days* from the date of submission of quotation.
3. Price quotation/s, to be denominated in Philippine peso shall include all taxes, duties and/or levies payable.
4. Quotations exceeding the Approved Budget for the Contract shall be rejected.
5. Award of contract shall be made to the lowest calculated and responsive quotation (for goods and infrastructure) or, the highest rated offer (for consulting services) which complies with the minimum technical specifications and other terms and conditions stated herein.
6. Any interlineations, erasures or overwriting shall be valid only if they are signed or initialed by you or any of your duly authorized representative/s.
7. The item/s shall be delivered according to the requirements specified in the Technical Specifications.
8. The DBM shall have the right to inspect and/or to test the goods to confirm their conformity to the technical specifications.
9. In case two or more bidders are determined to have submitted the Lowest Calculated Quotation/Lowest Calculated and Responsive Quotation, the DBM shall adopt and employ "draw lots" as the tie-breaking method to finally determine the single winning provider in accordance with GPPB Circular 06-2005.
10. **Payment shall be processed after delivery and upon the submission of the required supporting documents, in accordance with existing government accounting rules and regulations. Please note that the corresponding bank transfer fee, if any, shall be chargeable to the contractor's account.**
11. Payment shall be made promptly, but in no case later than sixty (60) days, through Land Bank's LDDAP-ADA/Bank Transfer facility after submission of billing statement/invoice and upon fulfillment of other obligations as stipulated in the contract as well as upon inspection and acceptance of the goods by the end user, subject to other payment terms as prescribed in this RFQ.
12. Liquidated damages equivalent to one tenth of one percent (0.1%) of the value of the goods not delivered within the prescribed delivery period shall be imposed per day of delay. The DBM **may** rescind the contract once the cumulative amount of liquidated damages reaches ten percent (10%) of the amount of the contract, without prejudice to other courses of action and remedies open to it.

13. In compliance with Section 4.3 of Appendix 33 of the 2016 Revised IRR of RA No. 9184 and consistent with Administrative Order No. 34, s. of 2020, the DBM shall publish in its official website and social media platform the following post-award information:

- a) Project name;
- b) Approved budget for the contract;
- c) Contract period;
- d) Name of the winning bidder and its official business address;
- e) Amount of contract awarded;
- f) Date of Award and Acceptance;
- g) Implementing office/unit/division/bureau of the concerned agency or instrumentality.

CONFORME:

Signature over Printed Name

Position/Designation

Office Telephone No.

Fax/Mobile No.

Email address/es

Section VI. Schedule of Requirements

The delivery schedule stipulates hereafter the date of delivery to the project site.

Item	Description	Quantity	Schedule
1	Provision of materials, tools, equipment, manpower, and supervision needed for the Project , in accordance with Annex "A" (Detailed Technical Specifications) of Section VII. Technical Specifications.	1 Lot	
2	Supply, delivery, and installation of Porcelain Urinal and accessories in accordance with Annex "A" (Detailed Technical Specifications) of Section VII. Technical Specifications.	42 sets	Within sixty (60) calendar days upon receipt of the Notice to Proceed (NTP) Working hours: a. Mondays to Fridays (6PM to 5AM only) – subject to change upon notice from the AS; and b. Saturdays, Sundays, and Holidays (allowed up to twenty-four [24] hours per day)
3	Installation of urinal divider panel , in accordance with Annex "A" (Detailed Technical Specifications) of Section VII. Technical Specifications.	27 pcs	
4	Dismantle and Removal of existing Urinals and accessories , in accordance with Annex "A" (Detailed Technical Specifications) of Section VII. Technical Specifications.	42 sets	

* The period for the performance of the obligations under the Contract shall not be beyond the validity of the appropriation for the Project.

I hereby certify to comply and deliver all the above requirements.

Name of Company/Bidder

Signature Over Printed Name of Representative

Date

Section VII. Technical Specifications

Bidders must state here either “Comply” or any equivalent term in the column “Bidder’s Statement of Compliance” against each of the individual parameters of each “Specification.”

Specifications	Bidder's Statement of Compliance
I. General Conditions/Specifications <i>(see attached Annex “A” [Detailed Technical Specifications], item 3.0)</i>	
II. Scope of Work <i>(see attached Annex “A” [Detailed Technical Specifications], item 4.0)</i>	
III. Warranty of the Supplier <i>(see attached Annex “A” [Detailed Technical Specifications], item 5.0)</i>	

I hereby certify to comply with all the above Technical Specifications.

Name of Company/Bidder

Signature Over Printed Name of Representative

Date

Detailed Technical Specifications

1. Project Title

Supply, Delivery and Installation of New Urinal and accessories and hpl urinal divider at DBM Central Office

2. Objective

To rehabilitate the DBM CO outdated urinals and damage.

3. General Conditions/Specifications

3.1. Conditions

During contract implementation, the Supplier shall deliver the obligations arising from this contract with the following conditions:

- 3.1.1. Conduct survey of the actual site condition.
- 3.1.2. Confinement of all works within the areas designated by the AS while strictly following the national laws for public safety, Workmen's Compensation Act 1906, and proper working conditions.
- 3.1.3. Provision of all needed materials, tools, equipment, manpower, and supervision for the project.
- 3.1.4. Cleaning, clearing and hauling of any debris, construction wastes, refuse, junk, etc.
- 3.1.5. Hauling of debris and waste materials for proper disposal outside the DBM compound. Clearances for the proper disposal shall be secured by the Supplier, at no additional cost to the DBM.
- 3.1.6. Provision and placement of temporary barricades, railings, fencing, warning signs and lights for the duration of the project, as needed.
- 3.1.7. Keep the premises free from accumulation of waste materials or rubbish caused by the works, at all times. At the completion of the work, the Supplier shall remove all its rubbish from and about the building and all its tools, scaffoldings and surplus materials.
- 3.1.8. Protection of all adjoining property from any damage.
- 3.1.9. Protection of the construction site from any untoward incident within its control.
- 3.1.10. Surrender of all dismantled urinal and accessories to the AS.

3.2. General Conditions of the Contract

- 3.2.1. The specifications shall be interpreted solely by the AS. No excuses shall be entertained for misinterpretation on the specifications after the award of the contract. All work, as deemed included in the Contract by the AS, shall be carried out properly by the Supplier.

- 3.2.2. The Supplier is required to submit samples or swatches before implementation of the same to eliminate the need for change order and site errors. Furthermore, the Supplier is required to verify with the AS all details, may it be for architectural, electrical and plumbing, before implementation of works.
- 3.2.3. Correction of work before final payment: The Supplier shall promptly replace and re-execute all work/s determined by the AS as failing to conform to the Contract, without expense to the DBM.
- 3.2.4. Damages caused in the dismantling due to the Supplier's fault shall be repaired/restored by the Supplier, at no additional cost to the DBM.
- 3.2.5. Correction of work after final payment: Neither the issuance of the certificate of acceptance nor payment nor any provision in the bidding documents shall relieve the Supplier of its responsibility for defects and damages resulting from faulty materials or poor workmanship which shall appear within a period of one (1) year from the date of acceptance of work by the DBM. The Supplier shall remedy any and all defects arising from faulty materials or poor workmanship and pay for any damage to other works resulting therefrom.
- 3.2.6. DBM shall not be responsible for: (a) death or injury of the Supplier's employees; and (b) any damage to the Supplier's equipment or materials.
- 3.2.7. The contractor shall conduct final testing and commissioning, to the satisfaction of AS.

3.3. Plumbing Works

3.3.1. Urinals Specs Sets

- 3.3.1.1. Product Dimension: W320mm x L345mm x H605mm (See Annex B)
- 3.3.1.2. Color: White
- 3.3.1.3. Flush Valve Drillings: Single
- 3.3.1.4. Included Components: Wall fixing set, Outlet rubber connector And Hanger for Urinal
- 3.3.1.5. Materials: Vitreous China w/ Anti-bacterial ceramic
- 3.3.1.6. Inlet: Top Inlet Urinal
- 3.3.1.7. Flush Rate: 1.9 to 3L

3.3.2. Urinal Push Control Flush Valves and Accessories

- 3.3.2.1. Self-Closing Urinal Flush Valve (See Annex B)
- 3.3.2.2. Water saving of just 0.8 lpf
- 3.3.2.3. Brass Body, Chrome Finish
- 3.3.2.4. 1/2" I.P.S. Inlet Connector
- 3.3.2.5. Flush Rate 0.9 to 1.9L

3.4. Civil Works

3.4.1. HPL Compact Board Urinal Divider

- 3.4.1.1. Dimension: W400mm x H 1000mm x 20mm thick
- 3.4.1.2. Color: For approval of AS
- 3.4.1.3. Shape: Straight shapes

3.4.1.4. Fixed on wall using SS 304 Heavy "L" Bracket.

3.4.1.5. Feature: waterproof, Anti-fungal, anti-bacterial,

4. Scope of Work

- 4.1. Mobilization
- 4.2. Clearing and cleaning of site
- 4.3. Dismantling/Removal of existing urinals including accessories and bracket along DBM CO Male comfort room DBM Bldg. 1, 2, 3 and multipurpose gym and turnover to AS.
- 4.4. Hauling of debris. The contractor shall be responsible for the hauling outside the DBM compound
- 4.5. Supply, delivery, and installation of New Urinal, flush valve and accessories.
- 4.6. Supply, delivery and installation of New HPL Compact urinal divider partition
- 4.7. Testing and commissioning of Urinal, flush valve and accessories and accessories
- 4.8. Demobilization

All works shall be done on standard engineering procedures and workmanship.

5. Warranty of the Supplier

One (1) Year Warranty shall commence on the day the AS issues the Certificate of Acceptance.

HR

Urinal Details

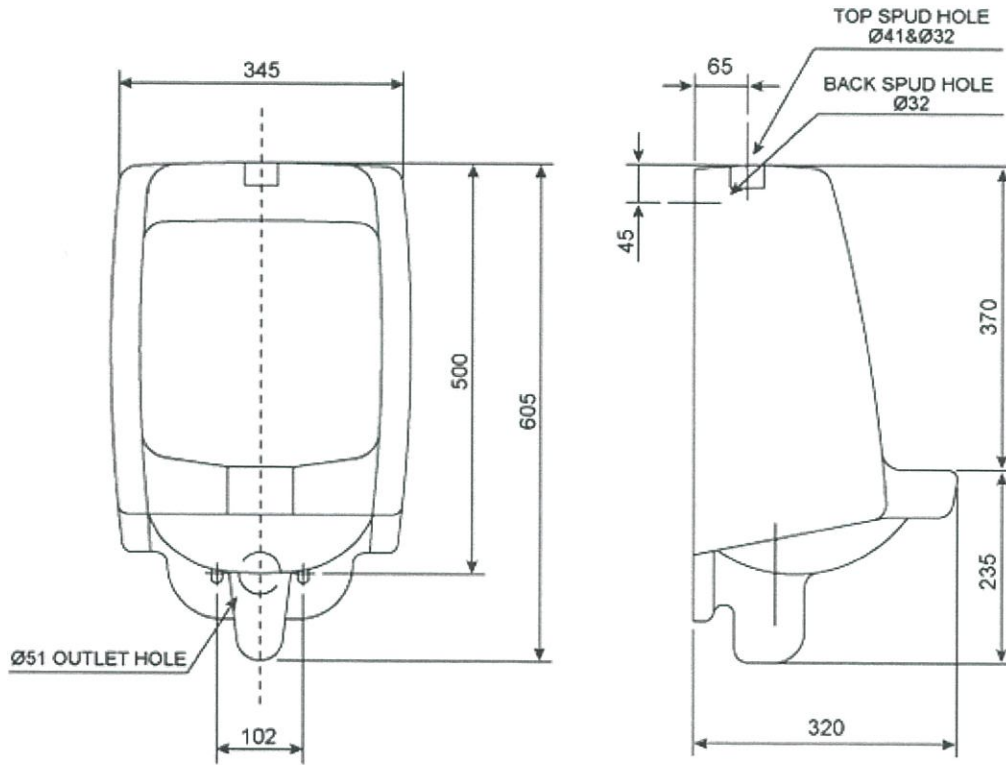

Push Button Flush Valve Details

