



REPUBLIC OF THE PHILIPPINES
DEPARTMENT OF BUDGET AND MANAGEMENT
REGIONAL OFFICE VII

PHILIPPINE BIDDING DOCUMENTS

for

ELECTRICAL SYSTEM REHABILITATION IN THE DBM ROVII MAIN BUILDING

DBMRO7-2022-22

TABLE OF CONTENTS

| | |
|--|-----------|
| Glossary of Terms, Abbreviations, and Acronyms | 4 |
| Section I. Invitation to Bid..... | 7 |
| Section II. Instructions to Bidders | 10 |
| 1. Scope of Bid..... | 11 |
| 2. Funding Information | 11 |
| 3. Bidding Requirements..... | 11 |
| 4. Corrupt, Fraudulent, Collusive, Coercive, and Obstructive Practices | 11 |
| 5. Eligible Bidders..... | 11 |
| 6. Origin of Associated Goods | 12 |
| 7. Subcontracts | 12 |
| 8. Pre-Bid Conference..... | 12 |
| 9. Clarification and Amendment of Bidding Documents..... | 12 |
| 10. Documents Comprising the Bid: Eligibility and Technical Components..... | 12 |
| 11. Documents Comprising the Bid: Financial Component | 13 |
| 12. Alternative Bids | 13 |
| 13. Bid Prices | 13 |
| 14. Bid and Payment Currencies..... | 14 |
| 15. Bid Security..... | 14 |
| 16. Sealing and Marking of Bids..... | 14 |
| 17. Deadline for Submission of Bids | 14 |
| 18. Opening and Preliminary Examination of Bids | 14 |
| 19. Detailed Evaluation and Comparison of Bids..... | 15 |
| 20. Post Qualification..... | 15 |
| 21. Signing of the Contract | 15 |
| Section III. Bid Data Sheet | 16 |
| Section IV. General Conditions of Contract..... | 19 |
| 1. Scope of Contract..... | 20 |
| 2. Sectional Completion of Works..... | 20 |
| 3. Possession of Site..... | 20 |
| 4. The Contractor's Obligations..... | 20 |
| 5. Performance Security | 21 |
| 6. Site Investigation Reports | 21 |

| | | |
|-----|--|-----------|
| 7. | Warranty..... | 21 |
| 8. | Liability of the Contractor..... | 21 |
| 9. | Termination for Other Causes..... | 21 |
| 10. | Dayworks | 22 |
| 11. | Program of Work..... | 22 |
| 12. | Instructions, Inspections and Audits | 22 |
| 13. | Advance Payment..... | 22 |
| 14. | Progress Payments | 22 |
| 15. | Operating and Maintenance Manuals..... | 23 |
| | Section V. Special Conditions of Contract..... | 24 |
| | Section VI. Specifications | 26 |
| | Section VII. Drawings..... | 31 |
| | Section VIII. Bill of Quantities..... | 34 |
| | Section IX. Checklist of Technical and Financial Documents..... | 46 |
| | Section X. Bid Forms..... | 54 |

Glossary of Terms, Abbreviations, and Acronyms

ABC – Approved Budget for the Contract.

ARCC – Allowable Range of Contract Cost.

BAC – Bids and Awards Committee.

Bid – A signed offer or proposal to undertake a contract submitted by a bidder in response to and in consonance with the requirements of the bidding documents. Also referred to as *Proposal* and *Tender*. (2016 revised IRR, Section 5[c])

Bidder – Refers to a contractor, manufacturer, supplier, distributor and/or consultant who submits a bid in response to the requirements of the Bidding Documents. (2016 revised IRR, Section 5[d])

Bidding Documents – The documents issued by the Procuring Entity as the bases for bids, furnishing all information necessary for a prospective bidder to prepare a bid for the Goods, Infrastructure Projects, and/or Consulting Services required by the Procuring Entity. (2016 revised IRR, Section 5[e])

BIR – Bureau of Internal Revenue.

BSP – Bangko Sentral ng Pilipinas.

CDA – Cooperative Development Authority.

Consulting Services – Refer to services for Infrastructure Projects and other types of projects or activities of the GOP requiring adequate external technical and professional expertise that are beyond the capability and/or capacity of the GOP to undertake such as, but not limited to: (i) advisory and review services; (ii) pre-investment or feasibility studies; (iii) design; (iv) construction supervision; (v) management and related services; and (vi) other technical services or special studies. (2016 revised IRR, Section 5[i])

Contract – Refers to the agreement entered into between the Procuring Entity and the Supplier or Manufacturer or Distributor or Service Provider for procurement of Goods and Services; Contractor for Procurement of Infrastructure Projects; or Consultant or Consulting Firm for Procurement of Consulting Services; as the case may be, as recorded in the Contract Form signed by the parties, including all attachments and appendices thereto and all documents incorporated by reference therein.

Contractor – is a natural or juridical entity whose proposal was accepted by the Procuring Entity and to whom the Contract to execute the Work was awarded. Contractor as used in these Bidding Documents may likewise refer to a supplier, distributor, manufacturer, or consultant.

CPI – Consumer Price Index.

DOLE – Department of Labor and Employment.

DTI – Department of Trade and Industry.

Foreign-funded Procurement or Foreign-Assisted Project – Refers to procurement whose funding source is from a foreign government, foreign or international financing institution as specified in the Treaty or International or Executive Agreement. (2016 revised IRR, Section 5[b]).

GFI – Government Financial Institution.

GOCC – Government-owned and/or –controlled corporation.

Goods – Refer to all items, supplies, materials and general support services, except Consulting Services and Infrastructure Projects, which may be needed in the transaction of public businesses or in the pursuit of any government undertaking, project or activity, whether in the nature of equipment, furniture, stationery, materials for construction, or personal property of any kind, including non-personal or contractual services such as the repair and maintenance of equipment and furniture, as well as trucking, hauling, janitorial, security, and related or analogous services, as well as procurement of materials and supplies provided by the Procuring Entity for such services. The term “related” or “analogous services” shall include, but is not limited to, lease or purchase of office space, media advertisements, health maintenance services, and other services essential to the operation of the Procuring Entity. (2016 revised IRR, Section 5[r])

GOP – Government of the Philippines.

Infrastructure Projects – Include the construction, improvement, rehabilitation, demolition, repair, restoration or maintenance of roads and bridges, railways, airports, seaports, communication facilities, civil works components of information technology projects, irrigation, flood control and drainage, water supply, sanitation, sewerage and solid waste management systems, shore protection, energy/power and electrification facilities, national buildings, school buildings, hospital buildings, and other related construction projects of the government. Also referred to as *civil works or works*. (2016 revised IRR, Section 5[u])

LGUs – Local Government Units.

NFCC – Net Financial Contracting Capacity.

NGA – National Government Agency.

PCAB – Philippine Contractors Accreditation Board.

PhilGEPS - Philippine Government Electronic Procurement System.

Procurement Project – refers to a specific or identified procurement covering goods, infrastructure project or consulting services. A Procurement Project shall be described, detailed, and scheduled in the Project Procurement Management Plan prepared by the agency which shall be consolidated in the procuring entity's Annual Procurement Plan. (GPPB Circular No. 06-2019 dated 17 July 2019)

PSA – Philippine Statistics Authority.

SEC – Securities and Exchange Commission.

SLCC – Single Largest Completed Contract.

UN – United Nations.

Section I. Invitation to Bid



REPUBLIC OF THE PHILIPPINES
DEPARTMENT OF BUDGET AND MANAGEMENT
REGIONAL OFFICE VII

Invitation to Bid for the Electrical System Rehabilitation in the DBM ROVII Main Building

1. The **Department of Budget and Management Regional Office VII**, through the **General Appropriations Act of FY 2022** intends to apply the sum of **Two Million Seven Hundred Thousand Pesos Only (P 2,700,000.00)** being the Approved Budget for the Contract (ABC) to payments under the contract for the **Electrical System Rehabilitation in the DBM ROVII Main Building** with Project Identification Number **DBMRO7-2022-22**. Bids received in excess of the ABC shall be automatically rejected at bid opening.
2. The **Department of Budget and Management Regional Office VII** now invites bids for the above Procurement Project. Completion of the Works is required **Ninety Calendar Days (90 CD) from the starting date of the project**. Bidders should have completed a contract similar to the Project. The description of an eligible bidder is contained in the Bidding Documents, particularly, in Section II (Instructions to Bidders).
3. Bidding will be conducted through open competitive bidding procedures using non-discretionary “*pass/fail*” criterion as specified in the 2016 revised Implementing Rules and Regulations (IRR) of Republic Act (RA) No. 9184.
4. Interested bidders may obtain further information from DBM Regional Office VII and inspect the Bidding Documents at the address given below during regular office hours from **9:00AM to 4:00PM**.
5. A complete set of Bidding Documents may be acquired by interested bidders from **December 3, 2022, until the deadline of bid submission on December 26, 2022, 9:00 AM** from the given address and email addresses below and upon payment of applicable fee for the bidding documents, pursuant to the latest Guidelines issued by the GPPB, in the amount of **P5,000.00**. The Procuring Entity shall allow the bidder to present its proof of payment for the fees in person or through electronic means.
6. The Department of Budget and Management Regional Office VII will hold a Pre-Bid Conference on **December 12, 2022 at 10:00AM** through face to face meeting at the DBM Regional Office VII, Sudlon, Lahug, Cebu City and/or online via google meet, which shall be open to prospective bidders.

7. Bids must be duly received by the BAC Secretariat through manual submission at the office address indicated below, **on or before 9:00 AM on December 26, 2022**. Late bids shall not be accepted.

The bidders shall drop their duly accomplished technical proposal including the eligibility requirements and financial proposals in two separate sealed envelopes in the bid box located at the address indicated below. Late bids shall not be accepted.

8. All bids must be accompanied by a bid security in any of the acceptable forms and in the amount stated in **ITB** Clause 15.
9. Bid opening shall be on **December 26, 2022, 10:00 AM** at the given address below and/or via google meet. Bids will be opened in the presence of the bidders' representatives who choose to attend the activity.
10. The **Department of Budget and Management Regional Office VII** reserves the right to reject any and all bids, declare a failure of bidding, or not award the contract at any time prior to contract award in accordance with Sections 35.6 and 41 of the 2016 revised Implementing Rules and Regulations (IRR) of RA No. 9184, without thereby incurring any liability to the affected bidder or bidders.
11. For further information, please refer to:

Cherry Cris A. Garate or Michelle Ann A. Remoroza
BAC Secretariat
Department of Budget and Management Regional Office No. VII
Sudlon, Lahug, Cebu City
cgarate@dbm.gov.ph / dbm-ro7bac@dbm.gov.ph
(032) 236-2875

12. Google meet links:
Pre-bid conference link (December 12, 2022 10:00AM):
meet.google.com/ngd-sudc-qpe

Bid Opening link (December 26, 2022, 10:00AM):
meet.google.com/cxn-qstw-ndd

December 3, 2022

Digitally signed by
Maraat Carlo Campos

CARLO C. MARAAT
BAC Chairperson



Section II. Instructions to Bidders

1. Scope of Bid

The Procuring Entity, **Department of Budget and Management Regional Office VII** invites Bids for the **Electrical System Rehabilitation in the DBM ROVII Main Building**, with Project Identification Number **DBMRO7-2022-22**.

The Procurement Project (referred to herein as “Project”) is for the construction of Works, as described in Section VI (Specifications).

2. Funding Information

2.1. The GOP through the source of funding as indicated below for **FY 2022** in the amount of **Two Million Seven Hundred Thousand Pesos Only (P 2,700,000.00)**.

2.2. The source of funding is the **FY 2022 General Appropriations Act**.

3. Bidding Requirements

The Bidding for the Project shall be governed by all the provisions of RA No. 9184 and its 2016 revised IRR, including its Generic Procurement Manual and associated policies, rules and regulations as the primary source thereof, while the herein clauses shall serve as the secondary source thereof.

Any amendments made to the IRR and other GPPB issuances shall be applicable only to the ongoing posting, advertisement, or invitation to bid by the BAC through the issuance of a supplemental or bid bulletin.

The Bidder, by the act of submitting its Bid, shall be deemed to have inspected the site, determined the general characteristics of the contracted Works and the conditions for this Project, such as the location and the nature of the work; (b) climatic conditions; (c) transportation facilities; (c) nature and condition of the terrain, geological conditions at the site communication facilities, requirements, location and availability of construction aggregates and other materials, labor, water, electric power and access roads; and (d) other factors that may affect the cost, duration and execution or implementation of the contract, project, or work and examine all instructions, forms, terms, and project requirements in the Bidding Documents.

4. Corrupt, Fraudulent, Collusive, Coercive, and Obstructive Practices

The Procuring Entity, as well as the Bidders and Contractors, shall observe the highest standard of ethics during the procurement and execution of the contract. They or through an agent shall not engage in corrupt, fraudulent, collusive, coercive, and obstructive practices defined under Annex “T” of the 2016 revised IRR of RA No. 9184 or other integrity violations in competing for the Project.

5. Eligible Bidders

- 5.1. Only Bids of Bidders found to be legally, technically, and financially capable will be evaluated.
- 5.2. The Bidder must have an experience of having completed a Single Largest Completed Contract (SLCC) that is similar to this Project, equivalent to at least fifty percent (50%) of the ABC adjusted, if necessary, by the Bidder to current prices using the PSA's CPI, except under conditions provided for in Section 23.4.2.4 of the 2016 revised IRR of RA No. 9184.

A contract is considered to be "similar" to the contract to be bid if it has the major categories of work stated in the **BDS**.
- 5.3. For Foreign-funded Procurement, the Procuring Entity and the foreign government/foreign or international financing institution may agree on another track record requirement, as specified in the Bidding Document prepared for this purpose.
- 5.4. The Bidders shall comply with the eligibility criteria under Section 23.4.2 of the 2016 IRR of RA No. 9184.

6. Origin of Associated Goods

There is no restriction on the origin of Goods other than those prohibited by a decision of the UN Security Council taken under Chapter VII of the Charter of the UN.

7. Subcontracts

- 7.1. The Procuring Entity has prescribed that **Subcontracting is not allowed**.

8. Pre-Bid Conference

The Procuring Entity will hold a pre-bid conference for this Project on the specified date and time through videoconferencing/webcasting via google meet as indicated in paragraph 6 of the **IB**.

9. Clarification and Amendment of Bidding Documents

Prospective bidders may request for clarification on and/or interpretation of any part of the Bidding Documents. Such requests must be in writing and received by the Procuring Entity, either at its given address or through electronic mail indicated in the **IB**, at least ten (10) calendar days before the deadline set for the submission and receipt of Bids.

10. Documents Comprising the Bid: Eligibility and Technical Components

- 10.1. The first envelope shall contain the eligibility and technical documents of the Bid as specified in **Section IX. Checklist of Technical and Financial Documents**.

- 10.2. If the eligibility requirements or statements, the bids, and all other documents for submission to the BAC are in foreign language other than English, it must be accompanied by a translation in English, which shall be authenticated by the appropriate Philippine foreign service establishment, post, or the equivalent office having jurisdiction over the foreign bidder's affairs in the Philippines. For Contracting Parties to the Apostille Convention, only the translated documents shall be authenticated through an apostille pursuant to GPPB Resolution No. 13-2019 dated 23 May 2019. The English translation shall govern, for purposes of interpretation of the bid.
- 10.3. A valid PCAB License is required, and in case of joint ventures, a valid special PCAB License, and registration for the type and cost of the contract for this Project. Any additional type of Contractor license or permit shall be indicated in the **BDS**.
- 10.4. A List of Contractor's key personnel (e.g., Project Manager, Project Engineers, Materials Engineers, and Foremen) assigned to the contract to be bid, with their complete qualification and experience data shall be provided. These key personnel must meet the required minimum years of experience set in the **BDS**.
- 10.5. A List of Contractor's major equipment units, which are owned, leased, and/or under purchase agreements, supported by proof of ownership, certification of availability of equipment from the equipment lessor/vendor for the duration of the project, as the case may be, must meet the minimum requirements for the contract set in the **BDS**.

11. Documents Comprising the Bid: Financial Component

- 11.1. The second bid envelope shall contain the financial documents for the Bid as specified in **Section IX. Checklist of Technical and Financial Documents**.
- 11.2. Any bid exceeding the ABC indicated in paragraph 1 of the **IB** shall not be accepted.
- 11.3. For Foreign-funded procurement, a ceiling may be applied to bid prices provided the conditions are met under Section 31.2 of the 2016 revised IRR of RA No. 9184.

12. Alternative Bids

Bidders shall submit offers that comply with the requirements of the Bidding Documents, including the basic technical design as indicated in the drawings and specifications. Unless there is a value engineering clause in the **BDS**, alternative Bids shall not be accepted.

13. Bid Prices

All bid prices for the given scope of work in the Project as awarded shall be considered as fixed prices, and therefore not subject to price escalation during contract implementation, except under extraordinary circumstances as determined by the NEDA

and approved by the GPPB pursuant to the revised Guidelines for Contract Price Escalation guidelines.

14. Bid and Payment Currencies

14.1. Bid prices may be quoted in the local currency or tradeable currency accepted by the BSP at the discretion of the Bidder. However, for purposes of bid evaluation, Bids denominated in foreign currencies shall be converted to Philippine currency based on the exchange rate as published in the BSP reference rate bulletin on the day of the bid opening.

14.2. Payment of the contract price shall be made in **Philippine Pesos**.

15. Bid Security

15.1. The Bidder shall submit a Bid Securing Declaration or any form of Bid Security in the amount indicated in the **BDS**, which shall be not less than the percentage of the ABC in accordance with the schedule in the **BDS**.

15.2. The Bid and bid security shall be valid until **April 25, 2023**. Any bid not accompanied by an acceptable bid security shall be rejected by the Procuring Entity as non-responsive.

16. Sealing and Marking of Bids

Each Bidder shall submit one copy of the first and second components of its Bid.

The Procuring Entity may request additional hard copies and/or electronic copies of the Bid. However, failure of the Bidders to comply with the said request shall not be a ground for disqualification.

If the Procuring Entity allows the submission of bids through online submission to the given website or any other electronic means, the Bidder shall submit an electronic copy of its Bid, which must be digitally signed. An electronic copy that cannot be opened or is corrupted shall be considered non-responsive and, thus, automatically disqualified.

17. Deadline for Submission of Bids

The Bidders shall submit on the specified date and time and either at its physical address or through online submission as indicated in paragraph 7 of the **IB**.

18. Opening and Preliminary Examination of Bids

18.1. The BAC shall open the Bids in public at the time, on the date, and at the place specified in paragraph 9 of the **IB**. The Bidders' representatives who are present shall sign a register evidencing their attendance. In case videoconferencing, webcasting or other similar technologies will be used, attendance of participants shall likewise be recorded by the BAC Secretariat.

In case the Bids cannot be opened as scheduled due to justifiable reasons, the rescheduling requirements under Section 29 of the 2016 revised IRR of RA No. 9184 shall prevail.

- 18.2. The preliminary examination of Bids shall be governed by Section 30 of the 2016 revised IRR of RA No. 9184.

19. Detailed Evaluation and Comparison of Bids

- 19.1. The Procuring Entity's BAC shall immediately conduct a detailed evaluation of all Bids rated "*passed*" using non-discretionary pass/fail criteria. The BAC shall consider the conditions in the evaluation of Bids under Section 32.2 of 2016 revised IRR of RA No. 9184.
- 19.2. If the Project allows partial bids, all Bids and combinations of Bids as indicated in the **BDS** shall be received by the same deadline and opened and evaluated simultaneously so as to determine the Bid or combination of Bids offering the lowest calculated cost to the Procuring Entity. Bid Security as required by **ITB** Clause 16 shall be submitted for each contract (lot) separately.
- 19.3. In all cases, the NFCC computation pursuant to Section 23.4.2.6 of the 2016 revised IRR of RA No. 9184 must be sufficient for the total of the ABCs for all the lots participated in by the prospective Bidder.

20. Post Qualification

Within a non-extendible period of five (5) calendar days from receipt by the Bidder of the notice from the BAC that it submitted the Lowest Calculated Bid, the Bidder shall submit its latest income and business tax returns filed and paid through the BIR Electronic Filing and Payment System (eFPS), and other appropriate licenses and permits required by law and stated in the **BDS**.

21. Signing of the Contract

The documents required in Section 37.2 of the 2016 revised IRR of RA No. 9184 shall form part of the Contract. Additional Contract documents are indicated in the **BDS**.

Section III. Bid Data Sheet

Bid Data Sheet

| ITB Clause | | | | | | | | | | | | | | | | |
|-----------------------|--|----------------------------|---------------------------|----------------------------|------------------|------------------------|---------|-----------------|------------------------|---------|---------------------|------------------------|---------|-----------------------|---------|---------|
| 5.2 | <p>The bidder must have completed an SLCC that is similar to the contract to be bid, and whose value, adjusted to current prices using the PSA consumer price indices, must be at least fifty percent (50%) of the ABC to be bid: Provided, however, that contractors under Small A and Small B categories without similar experience on the contract to be bid may be allowed to bid if the cost of such contract is not more than the Allowable Range of Contract Cost (ARCC) of their registration based on the guidelines as prescribed by the PCAB. (Section 23.4.2.4 of RA 9184 and its Revised Implementing Rules and Regulations updated as December 31, 2021)</p> <p>For this purpose, contracts similar to the Project shall refer to the electrical system rehabilitation and/or upgrading projects including, but not limited to electrical works, installation of panelboards, re-wiring of electrical wires, electrical audit and load computation and others.</p> | | | | | | | | | | | | | | | |
| 7.1 | Subcontracting is not allowed. | | | | | | | | | | | | | | | |
| 10.3 | No additional requirements. | | | | | | | | | | | | | | | |
| 10.4 | <p>The key personnel must meet the required minimum years of experience set below:</p> <table border="1" style="width: 100%; border-collapse: collapse;"> <thead> <tr> <th style="text-align: left;"><u>Key Personnel</u></th> <th style="text-align: center;"><u>General Experience</u></th> <th style="text-align: center;"><u>Relevant Experience</u></th> </tr> </thead> <tbody> <tr> <td>Project Engineer</td> <td style="text-align: center;">3 years</td> <td style="text-align: center;">3 years</td> </tr> <tr> <td>Foreman</td> <td style="text-align: center;">3 years</td> <td style="text-align: center;">3 years</td> </tr> <tr> <td>Electrical Engineer</td> <td style="text-align: center;">3 years</td> <td style="text-align: center;">3 years</td> </tr> <tr> <td>Electrical Technician</td> <td style="text-align: center;">3 years</td> <td style="text-align: center;">3 years</td> </tr> </tbody> </table> | <u>Key Personnel</u> | <u>General Experience</u> | <u>Relevant Experience</u> | Project Engineer | 3 years | 3 years | Foreman | 3 years | 3 years | Electrical Engineer | 3 years | 3 years | Electrical Technician | 3 years | 3 years |
| <u>Key Personnel</u> | <u>General Experience</u> | <u>Relevant Experience</u> | | | | | | | | | | | | | | |
| Project Engineer | 3 years | 3 years | | | | | | | | | | | | | | |
| Foreman | 3 years | 3 years | | | | | | | | | | | | | | |
| Electrical Engineer | 3 years | 3 years | | | | | | | | | | | | | | |
| Electrical Technician | 3 years | 3 years | | | | | | | | | | | | | | |
| 10.5 | <p>The minimum major equipment and tools requirements are the following:</p> <table border="1" style="width: 100%; border-collapse: collapse;"> <thead> <tr> <th style="text-align: left;"><u>Equipment</u></th> <th style="text-align: center;"><u>Capacity</u></th> <th style="text-align: center;"><u>Number of Units</u></th> </tr> </thead> <tbody> <tr> <td>Dump Truck</td> <td style="text-align: center;">No Minimum Requirement</td> <td style="text-align: center;">1</td> </tr> <tr> <td>Welding Machine</td> <td style="text-align: center;">No Minimum Requirement</td> <td style="text-align: center;">1</td> </tr> <tr> <td>Electrical Tools</td> <td style="text-align: center;">No Minimum Requirement</td> <td style="text-align: center;">1</td> </tr> </tbody> </table> | <u>Equipment</u> | <u>Capacity</u> | <u>Number of Units</u> | Dump Truck | No Minimum Requirement | 1 | Welding Machine | No Minimum Requirement | 1 | Electrical Tools | No Minimum Requirement | 1 | | | |
| <u>Equipment</u> | <u>Capacity</u> | <u>Number of Units</u> | | | | | | | | | | | | | | |
| Dump Truck | No Minimum Requirement | 1 | | | | | | | | | | | | | | |
| Welding Machine | No Minimum Requirement | 1 | | | | | | | | | | | | | | |
| Electrical Tools | No Minimum Requirement | 1 | | | | | | | | | | | | | | |
| 12 | No further instructions. | | | | | | | | | | | | | | | |
| 15.1 | <p>The bid security shall be in the form of a Bid Securing Declaration or any of the following forms and amounts:</p> <ol style="list-style-type: none"> a. The amount of not less than P 54,000.00 (<i>two percent (2%) of ABC</i>), if bid security is in cash, cashier's/manager's check, bank draft/guarantee or irrevocable letter of credit; b. The amount of not less than P 135,000.00 (<i>five percent (5%) of ABC</i>) if bid security is in Surety Bond. | | | | | | | | | | | | | | | |
| 19.2 | Partial bid is not allowed. The electrical system rehabilitation project is packages in a single lot and the lot shall be divided into sub-lots for the purpose of bidding, evaluation and contract award. | | | | | | | | | | | | | | | |

| | |
|----|--|
| 20 | <p>The bidder with the Lowest Calculated Bid shall submit ALL of the following post-qualification requirements:</p> <ol style="list-style-type: none"> 1. Photocopy/ies of Contract/s or Purchase Order/s of one of the following, as applicable: <ol style="list-style-type: none"> i. A single contract that is similar to the project and whose value must be at least fifty percent (50%) of the ABC to be bid; or ii. (a) at least two (2) similar contracts and the aggregate contract amounts should be equivalent to at least fifty (50%) of the ABC to be bid; and (b) the largest of these similar contracts must be equivalent to at least half of the percentage of the ABC as required above. 1. The corresponding proof/s of completion, which could either be: <ol style="list-style-type: none"> i. Certificate/s of Final Acceptance/Completion from the bidder's client/s; or ii. Official Receipt/s or Sales Invoice/s of the bidder covering the full amount of the contract/s 3. Latest Income and Business Tax Returns, filed and paid through the Electronic Filing and Payments System (EFPS), consisting of the following: <ol style="list-style-type: none"> i. 2021 Income Tax Return with proof of payment; and ii. VAT Returns (Form 2550M and 2550Q) or Percentage Tax Returns (2551M) with proof of payment covering the months from December 2021 to October 2022. <p>* Failure to submit copies of the Contracts or Purchase Orders with proof of completion is a valid ground for disqualification of the bidder.</p> <p>** In case the notice for the submission of post-qualification documents is sent via the bidder's email, it shall be considered as received by the bidder on the date and time the email was sent regardless whether or not the bidder acknowledged the said email. It shall be the bidder's responsibility to check its/his/her email for the purpose.</p> |
| 21 | None |

Section IV. General Conditions of Contract

1. Scope of Contract

This Contract shall include all such items, although not specifically mentioned, that can be reasonably inferred as being required for its completion as if such items were expressly mentioned herein. All the provisions of RA No. 9184 and its 2016 revised IRR, including the Generic Procurement Manual, and associated issuances, constitute the primary source for the terms and conditions of the Contract, and thus, applicable in contract implementation. Herein clauses shall serve as the secondary source for the terms and conditions of the Contract.

This is without prejudice to Sections 74.1 and 74.2 of the 2016 revised IRR of RA No. 9184 allowing the GPPB to amend the IRR, which shall be applied to all procurement activities, the advertisement, posting, or invitation of which were issued after the effectivity of the said amendment.

2. Sectional Completion of Works

If sectional completion is specified in the **Special Conditions of Contract (SCC)**, references in the Conditions of Contract to the Works, the Completion Date, and the Intended Completion Date shall apply to any Section of the Works (other than references to the Completion Date and Intended Completion Date for the whole of the Works).

3. Possession of Site

3.1 The Procuring Entity shall give possession of all or parts of the Site to the Contractor based on the schedule of delivery indicated in the **SCC**, which corresponds to the execution of the Works. If the Contractor suffers delay or incurs cost from failure on the part of the Procuring Entity to give possession in accordance with the terms of this clause, the Procuring Entity's Representative shall give the Contractor a Contract Time Extension and certify such sum as fair to cover the cost incurred, which sum shall be paid by Procuring Entity.

3.2 If possession of a portion is not given by the above date, the Procuring Entity will be deemed to have delayed the start of the relevant activities. The resulting adjustments in contract time to address such delay may be addressed through contract extension provided under Annex "E" of the 2016 revised IRR of RA No. 9184.

4. The Contractor's Obligations

The Contractor shall employ the key personnel named in the Schedule of Key Personnel indicating their designation, in accordance with **ITB** Clause 10.3 and specified in the **BDS**, to carry out the supervision of the Works.

The Procuring Entity will approve any proposed replacement of key personnel only if their relevant qualifications and abilities are equal to or better than those of the personnel listed in the Schedule.

5. Performance Security

- 5.1. Within ten (10) calendar days from receipt of the Notice of Award from the Procuring Entity but in no case later than the signing of the contract by both parties, the successful Bidder shall furnish the performance security in any of the forms prescribed in Section 39 of the 2016 revised IRR.
- 5.2. The Contractor, by entering into the Contract with the Procuring Entity, acknowledges the right of the Procuring Entity to institute action pursuant to RA No. 3688 against any subcontractor be they an individual, firm, partnership, corporation, or association supplying the Contractor with labor, materials and/or equipment for the performance of this Contract.

6. Site Investigation Reports

The Contractor, in preparing the Bid, shall rely on any Site Investigation Reports referred to in the SCC supplemented by any information obtained by the Contractor.

7. Warranty

- 7.1. In case the Contractor fails to undertake the repair works under Section 62.2.2 of the 2016 revised IRR, the Procuring Entity shall forfeit its performance security, subject its property(ies) to attachment or garnishment proceedings, and perpetually disqualify it from participating in any public bidding. All payables of the GOP in his favor shall be offset to recover the costs.
- 7.2. The warranty against Structural Defects/Failures, except that occasioned-on force majeure, shall cover the period from the date of issuance of the Certificate of Final Acceptance by the Procuring Entity. Specific duration of the warranty is found in the SCC.

8. Liability of the Contractor

Subject to additional provisions, if any, set forth in the SCC, the Contractor's liability under this Contract shall be as provided by the laws of the Republic of the Philippines.

If the Contractor is a joint venture, all partners to the joint venture shall be jointly and severally liable to the Procuring Entity.

9. Termination for Other Causes

Contract termination shall be initiated in case it is determined *prima facie* by the Procuring Entity that the Contractor has engaged, before, or during the implementation of the contract, in unlawful deeds and behaviors relative to contract acquisition and implementation, such as, but not limited to corrupt, fraudulent, collusive, coercive, and obstructive practices as stated in ITB Clause 4.

10. Dayworks

Subject to the guidelines on Variation Order in Annex “E” of the 2016 revised IRR of RA No. 9184, and if applicable as indicated in the **SCC**, the Dayworks rates in the Contractor’s Bid shall be used for small additional amounts of work only when the Procuring Entity’s Representative has given written instructions in advance for additional work to be paid for in that way.

11. Program of Work

11.1. The Contractor shall submit to the Procuring Entity’s Representative for approval the said Program of Work showing the general methods, arrangements, order, and timing for all the activities in the Works. The submissions of the Program of Work are indicated in the **SCC**.

11.2. The Contractor shall submit to the Procuring Entity’s Representative for approval an updated Program of Work at intervals no longer than the period stated in the **SCC**. If the Contractor does not submit an updated Program of Work within this period, the Procuring Entity’s Representative may withhold the amount stated in the **SCC** from the next payment certificate and continue to withhold this amount until the next payment after the date on which the overdue Program of Work has been submitted.

12. Instructions, Inspections and Audits

The Contractor shall permit the GOP or the Procuring Entity to inspect the Contractor’s accounts and records relating to the performance of the Contractor and to have them audited by auditors of the GOP or the Procuring Entity, as may be required.

13. Advance Payment

The Procuring Entity shall, upon a written request of the Contractor which shall be submitted as a Contract document, make an advance payment to the Contractor in an amount not exceeding fifteen percent (15%) of the total contract price, to be made in lump sum, or at the most two installments according to a schedule specified in the **SCC**, subject to the requirements in Annex “E” of the 2016 revised IRR of RA No. 9184.

14. Progress Payments

The Contractor may submit a request for payment for Work accomplished. Such requests for payment shall be verified and certified by the Procuring Entity’s Representative/Project Engineer. Except as otherwise stipulated in the **SCC**, materials and equipment delivered on the site but not completely put in place shall not be included for payment.

15. Operating and Maintenance Manuals

- 15.1. If required, the Contractor will provide “as built” Drawings and/or operating and maintenance manuals as specified in the **SCC**.
- 15.2. If the Contractor does not provide the Drawings and/or manuals by the dates stated above, or they do not receive the Procuring Entity’s Representative’s approval, the Procuring Entity’s Representative may withhold the amount stated in the **SCC** from payments due to the Contractor.

Section V. Special Conditions of Contract

Special Conditions of Contract

| GCC Clause | |
|------------|--|
| 2 | Completion of the Works is within Ninety (90) Calendar days beginning seven (7) calendar days from receipt of the Notice to Proceed. |
| 4.1 | No further instructions. |
| 6 | None |
| 7.2 | Warranty: The contractor shall submit a one (1) year Warranty Certificate upon turnover of the Project. Any defects in workmanship and/or materials which developed within the one (1) year warranty period shall be corrected at no additional cost to the DBM ROVII. |
| 10 | No dayworks are applicable to the contract. |
| 11.1 | The Contractor shall submit the Program of Work to the Procuring Entity's Representative within ten (10) calendar days of delivery of the Notice of Award. |
| 11.2 | The period between Program of Work updates is thirty (30) days . The amount to be withheld for late submission of an updated Program of Work is 1/50 or 1% of the contract value . |
| 13 | The amount of the advance payment is fifteen (15%) percent of the Contract Value and can be availed of upon the submission and receipt of a request for the release of the advance payment after the issuance of the Notice to Proceed (NTP) and posting of an irrevocable letter of credit in favor of the procuring entity. |
| 14 | No further instructions. |
| 15.1 | The date by which operating and maintenance manuals are required is ten (10) calendar days after the issuance of final acceptance. The date by which "as built" drawings are required is ten (10) calendar days after the issuance of final acceptance. |
| 15.2 | The amount to be withheld for failing to produce "as built" drawings and/or operating and maintenance manuals by the date required is 1/50 of 1% of the contract value . |

Section VI. Specifications

SUMMARY OF WORK

1.0 DESCRIPTION OF THE PROJECT

Complete all works for the **Electrical System Rehabilitation in the DBM ROVII Main Building**, including supply of all materials, equipment, and systems, as well as performance of all necessary labor and processes, in accordance with the plans, specifications, the Philippine Bidding Documents and other related contract documents.

All works to be done shall be in the highest quality of workmanship to the fullest intent and meaning of the plans and specifications unless otherwise specified.

2.0 PERMITS, LICENSES AND TAXES

- A. Secure and pay all permits, fees, licenses, taxes, etc. necessary for the execution of the **electrical system rehabilitation works**.
- B. Prepare a monthly progress report which shall include an overall progress chart based on actual physical accomplishment of construction work and a progress chart based on actual value of accomplished construction work, among others.

3.0 MOBILIZATION & TEMPORARY FACILITIES

- A. Mobilization of all necessary personnel, labor, tools, facilities, and equipment to commence work on the project.
- B. Construction, proper maintenance, and ordering of Temporary Facilities like storage structures such as warehouses or bodega, materials storage yard, worker housing, proper sanitation facilities, health and safety facilities, among others.
- C. Secure all existing equipment, materials, structures, and facilities for re-use with proper inventory. Provision of security and safety measures for the protection of the general public during the **electrical system rehabilitation works**.
- D. Take all necessary measures to protect all existing facilities, site development, and equipment from damage, loss and dirt. Contractor is responsible for the restoration of all existing equipment, materials, structures, and facilities damaged or otherwise affected during the **electrical system rehabilitation works**.
- F. The Contractor shall assume responsibility for losses or damages that may occur to the property or properties of the DBM ROVII during the construction period, provided it has been fully established after due investigation conducted by DBM ROVII and the Contractor that the said losses or damages were the result of the act, omission, negligence or fault of the Contractor's personnel on-site. However, the Contractor shall not be held responsible where such losses or damages were due to force majeure or fortuitous event.

The DBM ROVII shall immediately, or as soon thereafter, notify the Contractor in writing of any loss or damage, furnishing the latter a complete inventory of such loss or damage to be accompanied by supporting papers/documents to establish the fact of loss or damage as well as the value of the things lost or extent of damage done.

4.0 DEMOBILIZATION AND CLEANING

- A. Demobilize, dismantle and remove all temporary facilities, including all workmen's houses, construction equipment, tools, personnel and debris out of the project site and premises.
- B. Cleaning of the building and site to a spic and span state, ready for use.
- C. Contractor's personnel are prohibited to stay overnight at the Client's building unless authorized. The Contractor shall agree to subject its personnel assigned to the project site to security check by authorized security personnel when coming in and leaving the premises. The Contractor shall provide a logbook to monitor the attendance of the personnel deployed on site and inventory of materials stored/delivered to DBM ROVII.

5.0 SCOPE OF WORK

A. Preliminaries/General Requirements

- Processing of applicable permits and licenses.
- Installation of Project Billboard/Signboard.
- Provision of Materials for the occupational safety and health of onsite personnel.
- Mobilization/Demobilization which includes construction of temporary facilities and removal of structures and obstruction upon completion of the project.

B. Earthworks, Plain and Reinforced Concrete Works and Electrical Works

1. Earthworks

- Structure Excavation
- Gravel Fill

2. Plain and Reinforced Concrete Works

- Structural Concrete
- Reinforcing Steel (Deformed)

3. Electrical Works

- Installation of Conduits, Boxes and Fittings (Conduit Works/Conduit Rough-in)
- Installation of Wires and Wiring Devices
- Installation of Panelboard with Main and Branch Breakers

6.0 ADDITIONS AND REPAIRS

Demolitions and repairs due to Contractor's fault shall be done by the Contractor without extra compensation to the Owner.

7.0 ACCEPTANCE OF WORKS

A. As soon as the project is satisfactory inspected and it conforms to the plans and specifications, the contractor shall submit to the procuring entity a written notice that said project is completed and is subject to the latter's approval.

B. Within seven (7) days after receipt of notice, authorized representatives of the procuring entity shall execute notice of approval of the said project.

C. Upon inspection of an affidavit that the procuring entity has approved the completion of the project and acceptance thereof, the work is automatically terminated.

8.0 OTHERS

A. The Contractor must have a Project Engineer who will supervise the project onsite. The Contractor shall inform DBM ROVII in case of replacement/changes of personnel assigned at the project site. The replacement must have relevant qualifications and abilities equal to or better than those of the personnel as evidence by his/her training certification to be submitted to DBM ROVII.

B. Organization Set-up: The Contractor should have a physical office in Cebu Province with good office set-up, personnel, and office tools and equipment and working phone number for easy contact.

C. Liquidity of the Contractor: Current Asset minus Current Liabilities based on Balance Sheet as of December 31, 2021 matches at least 25% of the ABC.

Section VII. Plans / Drawings

GENERAL NOTES:

- ALL ELECTRICAL WORKS SHALL COMPLY IN ACCORDANCE WITH THESE PLANS AND SPECIFICATIONS. THE APPLICABLE PROVISIONS OF THE LATEST EDITION OF THE PHILIPPINE ELECTRICAL CODE (PEC), THE RULES AND REGULATIONS OF THE LOCAL ENFORCING AUTHORITY AND THE REQUIREMENTS OF THE LOCAL POWER COMPANY.
- THE ELECTRICAL SERVICE POWER IS 1-PHASE, 2-WIRE + GROUND 230V AC, 60Hz.
- WIRING METHOD SHALL BE AS FOLLOWS:
 - FEEDERS AND RISERS - INTERMEDIATE METALLIC CONDUIT
 - LIGHTING, POWER RECEPTACLE - POLYVINYL CHLORIDE CONDUIT
 - BRANCH CKT., & AUXILIARY THICK WALL
- ALL WIRES SHALL BE COPPER AND THERMOPLASTIC INSULATED TYPE "THHN" UNLESS OTHERWISE INDICATED IN THE PLAN. THE MINIMUM SIZE OF WIRE FOR POWER AND LIGHTING CIRCUIT HOMERUN SHALL BE 3.5mm AND INSULATED FOR 600 VOLTS. SMALLEST RACEWAY SHALL BE 15mm \varnothing TRADE/NOMINAL SIZE.
- ALL OUTLET BOXES SHALL BE GALVANIZED GAGE NO. 16 DEEP TYPE WITH FACTORY KNOCKOUTS.
- ALL MATERIALS TO BE USED SHALL BE BRAND NEW AND APPROVED TYPE FOR THE PARTICULAR LOCATION AND PURPOSE OF USAGE.
- EQUIPMENT GROUNDING SYSTEM SHALL BE PROVIDED TO THE ELECTRICAL SYSTEM AS PER PHILIPPINE ELECTRICAL CODE REQUIREMENT.
- MAIN FEEDER CONDUCTORS SHALL BE IDENTIFIED AS COLOR BLACK AND GROUNDING CONDUCTOR SHALL BE IDENTIFIED AS COLOR GREEN FOR THREE-PHASE AND COLOR WHITE FOR SINGLE PHASE.
- MOUNTING HEIGHT OF WIRING DEVICES SHALL AS FOLLOWS:
 - LIGHTING SWITCH - 1.50m ABOVE FINISH FLOOR LINE TO THE CENTER OF THE SWITCH
 - CONVENIENCE OUTLET - 0.30m ABOVE FINISH FLOOR LINE
 - PANEL BOARD - 1.80m ABOVE FINISH FLOOR LINE
 - EMERGENCY LIGHT OUTLET - 0.30m BELOW CEILING LINE

- PRIOR TO THE INSTALLATION OF ELECTRICAL LIGHTINGS FOR THIS BUILDING, AN INSULATION TEST IS TO BE CONDUCTED BY THE AWARDED BIDDER/CONTRACTOR WITH THE PRESENCE OF THE PROJECT ENGINEER OF BOTH PARTIES (CONTRACTOR AND DPWH) AND THE ELECTRICAL ENGINEERS OF THE DPWH-CCDEO
- A CERTIFICATION DULY SIGNED BY THE ELECTRICAL ENGINEER (REE) ALREADY TESTED AND SHALL BE AMONG THE SUPPORTING DOCUMENT IN THE CONTRACTOR'S CLAIM FOR PAYMENT TO ENSURE THAT THE ELECTRICAL INSTALLATION ARE SAFE AND TESTED PRIOR TO PAYMENT.
- IN THE FINAL INSPECTION OF THE DISTRICT INSPECTORATE TEAM (DIT) THE PROJECT ENGINEER SHALL CONDUCT INSPECTION WITH THE PARTICIPATION OF THE ELECTRICAL ENGINEER (REE) AND SUBSEQUENTLY PREPARES "PUNCH LIST" REFLECTING ALL DEFICIENCIES NOTED DULY SIGNED BY BOTH THE PROJECT ENGINEER AND THE ELECTRICAL ENGINEER (REE).

LEGEND:

| SYMBOL | DESCRIPTION |
|--------|--|
| | PANEL BOARD, MARKED AS BASED ON PLAN |
| | MAIN DISTRIBUTION PANEL, MARKED AS BASED ON PLAN |
| | MANUAL TRANSFER SWITCH, MARKED AS BASED ON PLAN |
| | WALL MOUNT SINGLE DOOR TYPE POWDER COATED CARBON STEEL 3R WITH BACK PANEL AND 600AMPS G.E. CIRCUIT BREAKER BOLT-ON TYPE. |
| | 12"x12"x6" PULLBOX POWDER COATED CARBON STEEL 3R WITH BACK PANEL |
| | SERVICE METER |
| | SERVICE ENTRANCE |

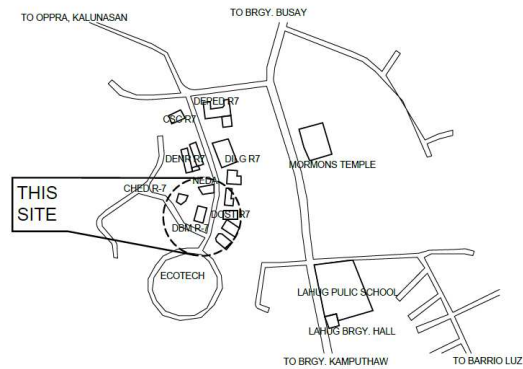

3 VICINITY MAP
E-1 NOT TO SCALE

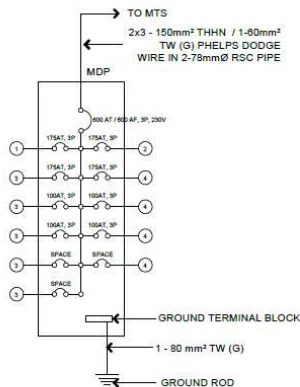

4 SINGLE LINE DIAGRAM - MDP
E-1 NOT TO SCALE

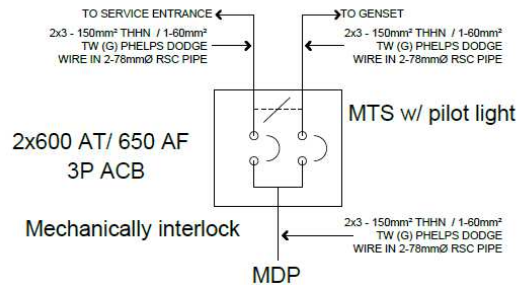

5 SINGLE LINE DIAGRAM - MTS
E-1 NOT TO SCALE

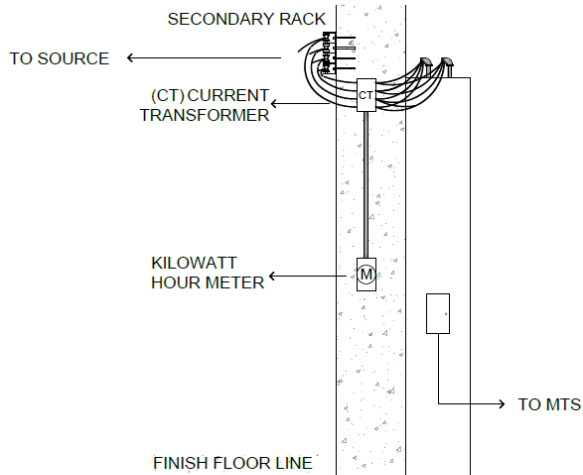

6
E-1
S E C O N D A R Y R A C K A N D S E R V I C E E N T R A N C E D E T A I L
N O T T O S C A L E

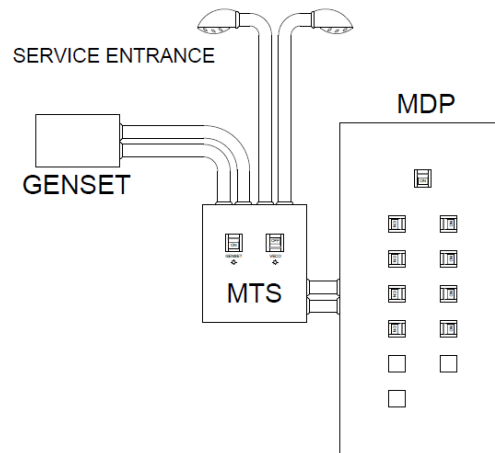

1
E-2
S E R V I C E E N T R A N C E A N D P A N E L B O A R D S D E T A I L
N O T T O S C A L E

LOAD SCHEDULE "MDP"

| | | Panel: MDP Phase:3 | | Volts:230 | | Wire:3+GROUND | | | | Demand Factor: 80% | | | | | | | | |
|------------|-----------------|--------------------|------|-----------|-------|---------------|-------------|----|----|--------------------|-------|------------|----|-----|--------|-----------|------------------|-------------|
| CKT# | LOAD DISCRPTION | CODE | UNIT | VA | Kw | VA-total | AMPERE LOAD | | | | PHASE | PROTECTION | | | INTERP | WIRE SIZE | GROUND WIRE SIZE | CONDUITSIZE |
| | | | | | | | AB | CA | BC | ACB | | Ø | AT | AF | | | | |
| 1 | DP1F | | | 32200w | 32200 | | | | | 3 | 175 | 175 | 3 | ACB | 15 | 2x30 | 22 | 53 |
| 2 | DP2F | | | 29950w | 29950 | | | | | 3 | 175 | 175 | 3 | ACB | 15 | 2x30 | 22 | 53 |
| 3 | DP3F | | | 30550w | 30550 | | | | | 3 | 175 | 175 | 3 | ACB | 15 | 2x30 | 22 | 53 |
| 4 | DP4F | | | 31150w | 31150 | | | | | 3 | 175 | 175 | 3 | ACB | 15 | 2x30 | 22 | 53 |
| 5 | PB5 | | | 17500w | 17500 | | | | | 3 | 100 | 100 | 3 | ACB | 10 | 2x30 | 22 | 53 |
| 6 | PB6 | | | 15900w | 15900 | | | | | 3 | 100 | 100 | 3 | ACB | 10 | 2x30 | 22 | 53 |
| | PB7 | | | 16250w | 16250 | | | | | 3 | 100 | 100 | 3 | ACB | 10 | 2x30 | 22 | 53 |
| | PB8 | | | 15550w | 15550 | | | | | 3 | 100 | 100 | 3 | ACB | 10 | 2x30 | 22 | 53 |
| | SPACE | | | 5000w | 5000 | | | | | | | | | | | | | |
| | SPACE | | | 5000w | 5000 | | | | | | | | | | | | | |
| | SPACE | | | 5000w | 5000 | | | | | | | | | | | | | |
| Main/Total | | | | | | 204050 | | | | | | | | | | | | |

| | | | |
|---|---|--|--|
| Computations: Main Feeder Line $I_L = \frac{(204050 \times .8) + (32200 \times 1.25)}{230(1.732)}$ $I_L = 510.9 \text{ A}$ use: 2x3-150mm² THW, Cu. Stranded 1-60mm² TW, Cu. Stranded 2-78mmØ Conduit size RSC PIPE | Feeder Protection $I_t = \frac{(204050 \times .8) + (32200 \times 2)}{230(1.732)}$ $I_t = 571.44 \text{ A}$ use: 600 AT / 600 AF 230V, 3P BOLT ON TYPE, G.E | Gen-Set: @ 0.8 Capacity Factor $I_t = \frac{204050}{0.8}$ $= 255 \text{ Kva}$ use: 255 Kva 240 V- 60 cps , 3Ø Generator | Transformer $P = \text{MDP}$ $= 204050$ $= 204 \text{ Kva}$ use: 3 - 75 Kva pole mounted |
|---|---|--|--|

2
E-2
S C H E D U L E O F L O A D S
N O T T O S C A L E

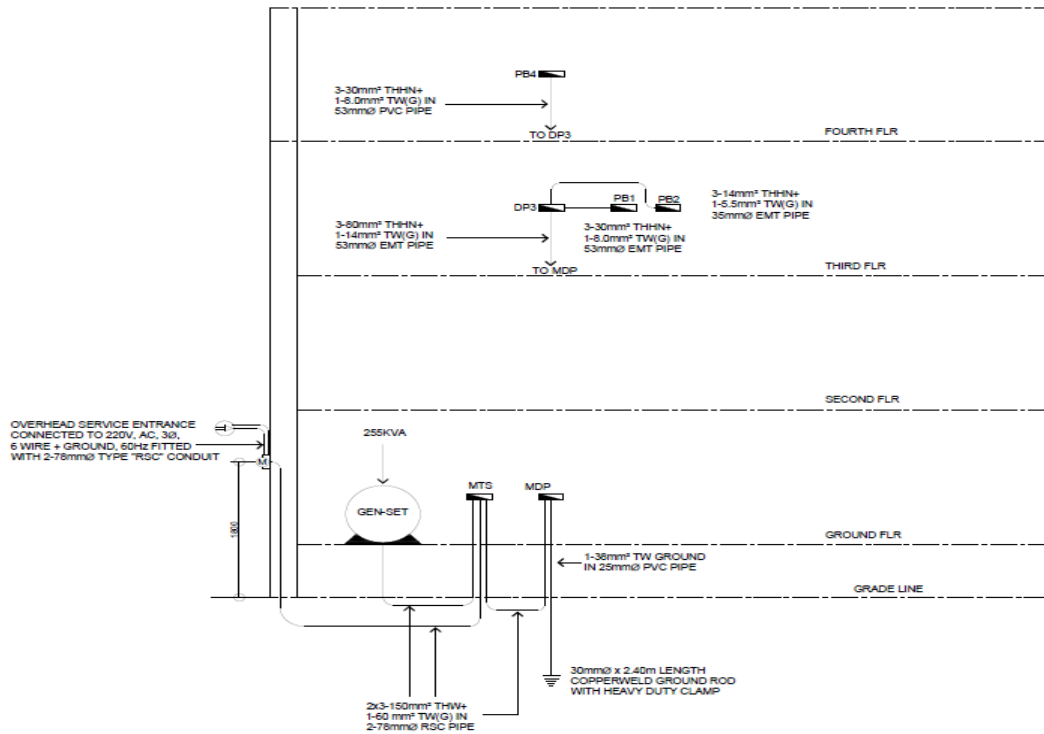

1 R I S E R D I A G R A M
E-3 N O T T O S C A L E

SCHEMATIC DIAGRAM

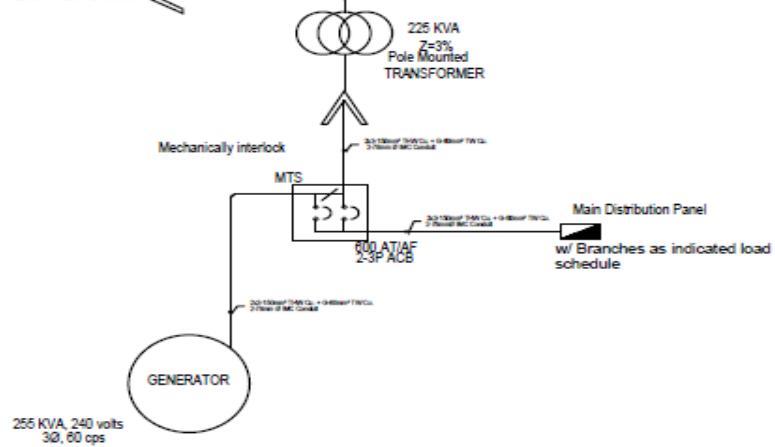

TRANSFORMER SYSTEM TIE-UP AND GEN-SET CAPACITY

2 S C H E M A T I C D I A G R A M
E-3 N O T T O S C A L E

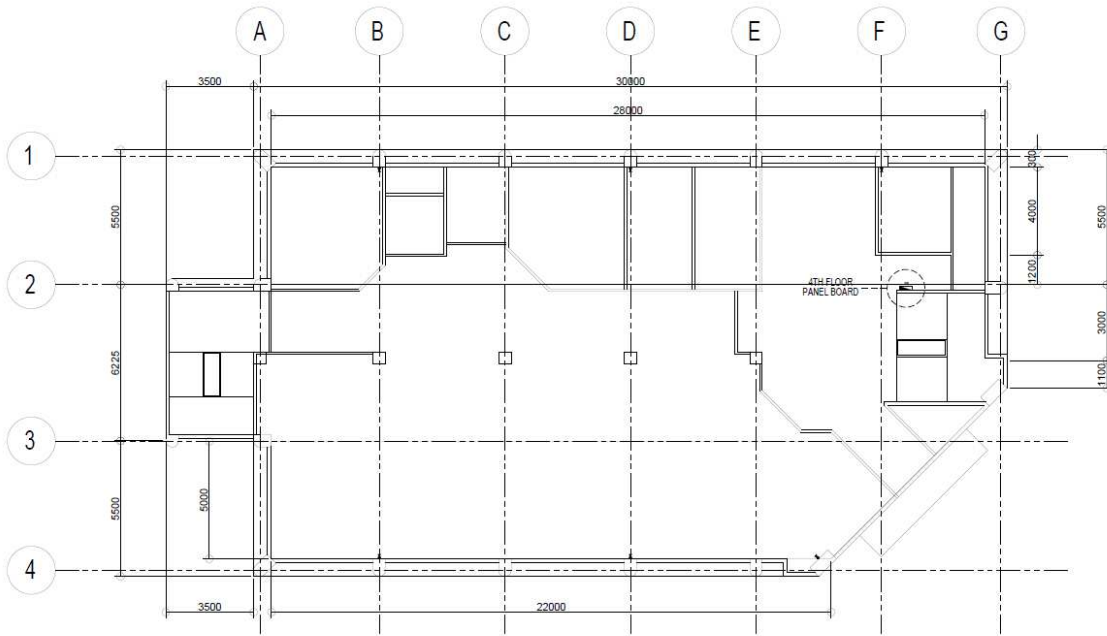

1 FOURTH FLOOR ELECTRICAL PLAN
 E-6 SCALE 1:100MTS

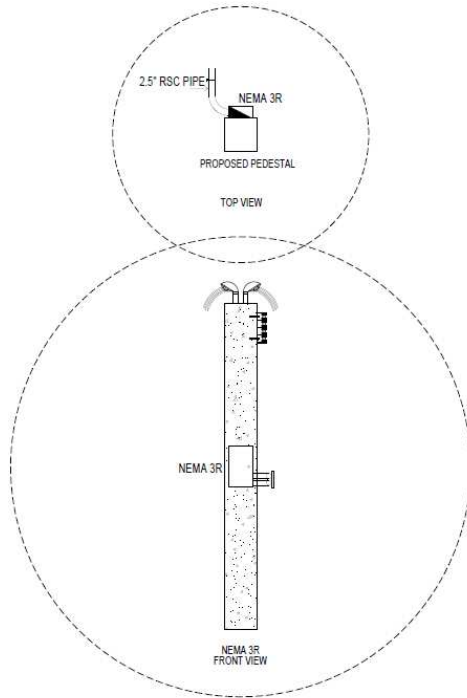

1 PROPOSE PEDESTAL DETAILS
 E-7 NOT TO SCALE

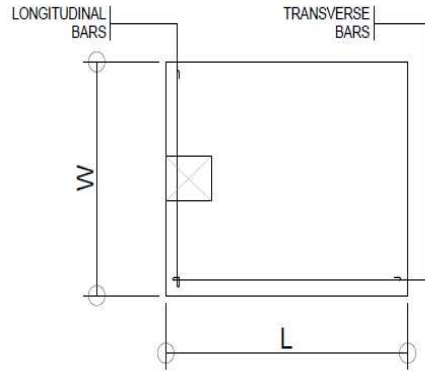
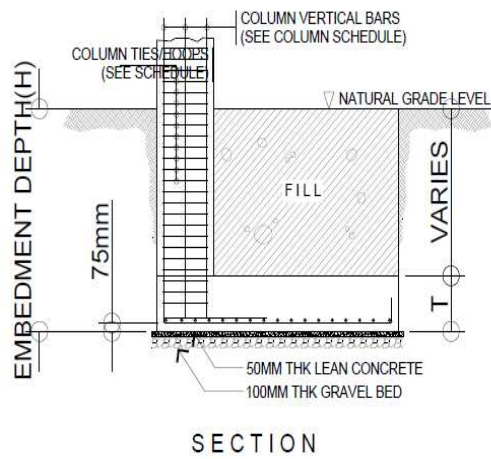

REINFORCEMENT LAYOUT PLAN

2 COLUMN AND FOOTING DETAIL
E-7 NOT TO SCALE

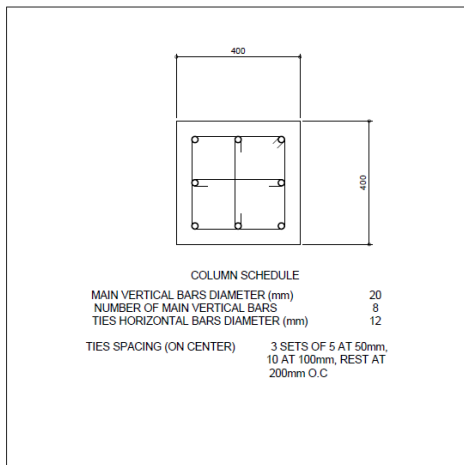

| MARK | L (mm) | W (mm) | T (mm) | H (mm) | REINFORCEMENT | | REMARKS |
|------|-----------|-----------|-----------|-----------|---------------|----------|-----------|
| | | | | | LONGITUDINAL | TRAVERSE | |
| F1 | 1400 | 1400 | 300 | 1000 | 12-16mmØ | 12-16mmØ | ECCENTRIC |

3 COLUMN DETAIL
E-7 NOT TO SCALE

4 FOOTING DETAIL
E-7 NOT TO SCALE

Section VIII. Bill of Quantities

Project: **Electrical System Rehabilitation in the DBM ROVII Main Building**
 Location: **Sudlon, Lahug, Cebu City**

| Rehabilitation of Electrical System in the DBM ROVII Main Building | | | | | | | | | |
|--|---|--------|-------|--------------------|-----------|---------------|-----------|------------|------------|
| ITEM NO. | DESCRIPTION | QTY | UNIT | ITEMIZED BREAKDOWN | | | | TOTAL COST | Percentage |
| | | | | DIRECT COST | | INDIRECT COST | | | |
| | | | | TOTAL | UNIT COST | TOTAL | UNIT COST | | |
| PART I | OTHER GENERAL REQUIREMENTS | | | | | | | | |
| I.A | Permits and Clearances | 1.00 | L.S | | | | | - | |
| I.B | Project Billboard / Signboard | 1.00 | ea. | | | | | - | |
| I.C | Occupational Safety and Health Program | 2.00 | mos. | | | | | - | |
| I.D | Mobilization / Demobilization | 1.00 | L.S | | | | | - | |
| | TOTAL OF PART I | | | - | | - | | - | |
| PART II | EARTHWORKS, PLAIN AND REINFORCED CONCRETE WORKS AND ELECTRICAL WORKS | | | | | | | | |
| PART A | EARTHWORKS | | | | | | | | |
| II.A | Structure Excavation (Common Soil) (includes disposal) | 1.50 | cu.m. | | | | | - | |
| II.B | Gravel Fill | 0.10 | cu.m. | | | | | - | |
| | TOTAL OF PART A | | | - | | - | | - | |
| PART B | PLAIN AND REINFORCED CONCRETE WORKS | | | | | | | | |
| II.C | Structural Concrete, Class A, 28 Days | 0.84 | cu.m. | | | | | - | |
| II.D | Reinforcing Steel (Deformed), Grade 40 | 155.20 | kg. | | | | | - | |
| | TOTAL OF PART B | | | - | | - | | - | |
| PART C | ELECTRICAL WORKS | | | | | | | | |
| II.E | Conduits, Boxes & Fittings (Conduit Works/Conduit Rough-in) | 1.00 | L.S | | | | | - | |
| II.F | Wires and Wiring Devices | 1.00 | L.S | | | | | - | |
| II.G | Panelboard with Main & Branch Breakers | 1.00 | L.S | | | | | - | |
| | TOTAL OF PART C | | | - | | - | | - | |
| | GRAND TOTAL | | | - | | - | | - | |

| | | | | | |
|--|--|-------------|-----------------|------------------|---------------------|
| Item No. / Description : 1.A - Permits and Clearances | | | | | |
| Unit of Measurement : L.S | | | | | |
| Output per hour : 1.00 | | | | | |
| | Name and Specification | Unit | Quantity | Unit Cost | Amount (PhP) |
| A.1 | Materials | | | | |
| | a. As built plan | set | 1.00 | | - |
| | b. Permits | set | 1.00 | | - |
| | Sub - Total for A.1 | | | | - |
| B.1 | Direct Unit Cost (A.1) | | | | - |
| C.1 | Value Added Tax (VAT) - (7% of B.1) | | | 7% | - |
| D.1 | Total Unit Cost (B.1+C.1) | | | | - |

| | | | | | |
|---|--|------------------------|---------------------|--------------------|---------------------|
| Item No. / Description : 1.B Project Billboard / Signboard | | | | | |
| Unit of Measurement : ea. | | | | | |
| Output per hour : 0.10 | | | | | |
| | Designation | No. of Person/s | No. of Hours | Hourly Rate | Amount (PhP) |
| A.1 | Labor | | | | |
| | a. Construction Foreman | 1 | 1.00 | | - |
| | b. Skilled Labor | 1 | 1.00 | | - |
| | c. Unskilled Labor | 1 | 1.00 | | - |
| | Sub - Total for A.1 | | | | - |
| B.1 | Output per hour | | | | 0.10 |
| C.1 | Direct Unit Cost (A.1 ÷ B.1) | | | | - |
| | Name and Specification | Unit | Quantity | Unit Cost | Amount (PhP) |
| D.1 | Materials (Billboard) | | | | |
| | a. Tarpaulin | sq.ft. | 64.00 | | - |
| | b. Good Lumber | bd-ft | 46.00 | | - |
| | c. Plywood Marine, 1/2" thk. x 4' x 8' | pc | 1.00 | | - |
| | d. Assorted CWN (1kg. / 100 bd.ft. of Lumber) | kg | 0.75 | | - |
| | Sub - Total for D.1 | | | | - |
| E.1 | Direct Unit Cost (C.1 + D.1) | | | | - |
| F.1 | Overhead, Contingencies & Miscellaneous (OCM) (5% of E.1) | | | 5% | - |
| G.1 | Engineering Overh.(5% of E.1) | | | 5% | - |
| H.1 | Contractor's Profit (CP) - (8% of E.1) | | | 8% | - |
| I.1 | Value Added Tax (VAT) - ((E.1+F.1+G.1+H.1)*7%) | | | 7% | - |
| J.1 | Total Unit Cost | | | | - |

| | | | | | |
|--|-------------------------------------|------------------------|--------------------|-------------------|---------------------|
| Item No. / Description : 1.C Occupational Safety and Health Program | | | | | |
| Unit of Measurement : mos. | | | | | |
| Output per hour : 1.00 | | | | | |
| | Designation | No. of Person/s | No. of Days | Daily Rate | Amount (PhP) |
| A.1 | Labor | | | | |
| | b. First-Aider (Full Time) | 1 | 20.00 | | - |
| | Sub - Total for A.1 | | | | - |
| B.1 | Total (A.1) | | | | - |
| C.1 | Output per hour | | | | 1.00 |
| D.1 | Direct Unit Cost (B.1 ÷ C.1) | | | | - |
| | Name and Specification | Unit | Quantity | Unit Cost | Amount (PhP) |
| E.1 | Materials | | | | |
| | a. Safety Shoes (Different Sizes) | man-days | 18 | | - |
| | b. Safety Helmet (Free Size) | man-days | 18 | | - |
| | c. Safety Gloves (Free Size) | man-days | 18 | | - |
| | d. Vest | man-days | 18 | | - |
| | e. Rain Coat | man-days | 18 | | - |
| | f. Dust Mask | man-days | 18 | | - |
| | g. Eye Goggles | man-days | 18 | | - |
| | h. Ear Muff | man-days | 18 | | - |
| | i. Body Harness and Lanyard | man-days | 18 | | - |
| | Sub - Total for E.1 | | | | - |
| F.1 | Direct Unit Cost (D.1 + E.1) | | | | - |
| G.1 | Contractor's Profit (CP) | | | 8% | - |
| H.1 | Value Added Tax (VAT) | | | 7% | - |
| I.1 | Total Unit Cost | | | | - |

Item No. / Description : **1.D - Mobilization / Demobilization**
Unit of Measurement : L.S
Output per hour : 1.00

| | Designation | Unit | Quantity | Unit Cost | Amount (PhP) |
|--------------|--|---------------|-------------|------------|--------------|
| Labor | | | | | |
| A.1 | 1. Temporary Facilities | lot | 1.00 | | - |
| | 2. Removal of Structures and Obstruction (includes disposal) | lot | 1.00 | | - |
| | Sub - Total for A.1 | | | | - |
| | Name and Capacity | No. of Unit/s | No. of Days | Daily Rate | Amount (PhP) |
| B.1 | Equipment | | | | |
| | a. Dump Truck (12cu.yd.), 290HP | 1 | 1.50 | | - |
| | Sub - Total for B.1 | | | | - |
| C.1 | Total (A.1 + B.1) | | | | - |
| D.1 | Output per hour | | | | 1.00 |
| E.1 | Direct Unit Cost (C.1 ÷ D.1) | | | | - |
| F.1 | Value Added Tax (VAT) | | | 7% | - |
| G.1 | Total Unit Cost (E.1+F.1) | | | | - |

Item No. / Description : **II.A - Structure Excavation (Common Soil) (includes disposal)**
Unit of Measurement : cu.m.
Output per hour : 20.00

| | Designation | No. of Person/s | No. of Hours | Hourly Rate | Amount (PhP) |
|--------------|--|-----------------|--------------|-------------|--------------|
| Labor | | | | | |
| A.1 | a. Construction Foreman | 1 | 1.00 | | - |
| | b. Unskilled Labor | 3 | 1.00 | | - |
| | Sub - Total for A.1 | | | | - |
| | Name and Capacity | No. of Unit/s | No. of Hours | Hourly Rate | Amount (PhP) |
| B.1 | Equipment | | | | |
| | a. Dump Truck (12 cu.yd.), 290 HP | 2 | 1.00 | | - |
| | Minor Tools (10 % of Labor Cost) | | | | - |
| | Sub - Total for B.1 | | | | - |
| C.1 | Total (A.1 + B.1) | | | | - |
| D.1 | Output per hour | | | | 20.00 |
| E.1 | Direct Unit Cost (C.1 ÷ D.1) | | | | - |
| F.1 | Overhead, Contingencies & Miscellaneous (OCM) (5% of F.1) | | | 5% | - |
| G.1 | Engineering Overh(5% of F.1) | | | 5% | - |
| H.1 | Contractor's Profit (CP) - (8% of F.1) | | | 8% | - |
| I.1 | Value Added Tax (VAT) - ((E.1+F.1+G.1+H.1)*7%) | | | 7% | - |
| J.1 | Total Unit Cost - (E.1+F.1+G.1+H.1+I.1+K.1) | | | | - |

| | | | | | |
|------------------------|--|------------------------|---------------------|--------------------|---------------------|
| Item No. / Description | | : II.B - Gravel Fill | | | |
| Unit of Measurement | | : cu.m. | | | |
| Output per hour | | : 1.20 | | | |
| | Designation | No. of Person/s | No. of Hours | Hourly Rate | Amount (PhP) |
| | Labor | | | | |
| A.1 | a. Construction Foreman | 1 | 1.00 | | - |
| | b. Unskilled Labor | 3 | 1.00 | | - |
| | Sub - Total for A.1 | | | | - |
| | Name and Capacity | No. of Unit/s | No. of Hours | Hourly Rate | Amount (PhP) |
| | Equipment | | | | |
| B.1 | Minor Tools (10% of Labor Cost) | | | | - |
| | Sub - Total for B.1 | | | | - |
| C.1 | Total (A.1 + B.1) | | | | - |
| D.1 | Output per hour | | | | 1.20 |
| E.1 | Direct Unit Cost (C.1 ÷ D.1) | | | | - |
| | Name and Specification | Unit | Quantity | Unit Cost | Amount (PhP) |
| | Materials | | | | |
| F.1 | a. Gravel (w/ 5% Shrinkage Factor) | cu.m. | 1.05 | | - |
| | Sub - Total for F.1 | | | | - |
| G.1 | Direct Unit Cost (E.1 + F.1) | | | | - |
| H.1 | Overhead, Contingencies & Miscellaneous (OCM) (5% of G.1) | | | 5% | - |
| I.1 | Engineering Overh (5% of G.1) | | | 5% | - |
| J.1 | Contractor's Profit (CP) - (8% of G.1) | | | 8% | - |
| K.1 | Value Added Tax (VAT) - ((G.1+H.1+J.1+I.1)*7%) | | | 7% | - |
| L.1 | Total Unit Cost - (G.1+(H.1+J.1+I.1+K.1)) | | | | - |

| | | | | | |
|------------------------|--|--|---------------------|--------------------|---------------------|
| Item No. / Description | | : II.C - Structural Concrete, Class A, 28 Days | | | |
| Unit of Measurement | | : cu.m. | | | |
| Output per hour | | : 0.36 | | | |
| | Designation | No. of Person/s | No. of Hours | Hourly Rate | Amount (PhP) |
| | Labor | | | | |
| A.1 | a. Construction Foreman | 1 | 1.00 | | - |
| | b. Skilled Labor | 1 | 1.00 | | - |
| | c. Unskilled Labor | 4 | 1.00 | | - |
| | Sub - Total for A.1 | | | | - |
| | Name and Capacity | No. of Unit/s | No. of Hours | Hourly Rate | Amount (PhP) |
| | Equipment | | | | |
| B.1 | a. Concrete Mixer (4-6 cu.ft./min.), One-Bagger | 1 | 1.00 | | - |
| | Minor Tools (10% of Labor Cost) | | | | - |
| | Sub - Total for B.1 | | | | - |
| C.1 | Total (A.1 + B.1) | | | | - |
| D.1 | Output per hour | | | | 0.36 |
| E.1 | Direct Unit Cost (C.1 ÷ D.1) | | | | - |
| | Name and Specification | Unit | Quantity | Unit Cost | Amount (PhP) |
| | Materials | | | | |
| F.1 | a. Portland Cement | bags | 9.10 | | - |
| | b. Sand | cu.m. | 0.50 | | - |
| | c. Gravel | cu.m. | 1.00 | | - |
| | Sub - Total for F.1 | | | | - |
| G.1 | Direct Unit Cost (E.1 + F.1) | | | | - |
| H.1 | Overhead, Contingencies & Miscellaneous (OCM) (5% of G.1) | | | 5% | - |
| I.1 | Engineering Overh (5% of G.1) | | | 5% | - |
| J.1 | Contractor's Profit (CP) - (8% of G.1) | | | 8% | - |
| K.1 | Value Added Tax (VAT) - ((G.1+H.1+J.1+I.1)*7%) | | | 7% | - |
| L.1 | Total Unit Cost - (G.1+(H.1+J.1+I.1+K.1)) | | | | - |

| | | | | | |
|---|--|------------------------|---------------------|--------------------|---------------------|
| Item No. / Description : II.D - Reinforcing Steel (Deformed), Grade 40 | | | | | |
| Unit of Measurement : kg. | | | | | |
| Output per hour : 129.09 | | | | | |
| | Designation | No. of Person/s | No. of Hours | Hourly Rate | Amount (PhP) |
| Labor | | | | | |
| A.1 | a. Construction Foreman | 1 | 1.00 | | - |
| | b. Skilled Labor | 3 | 1.00 | | - |
| | c. Unskilled Labor | 12 | 1.00 | | - |
| | Sub - Total for A.1 - As Submitted | | | | - |
| | Name and Capacity | No. of Unit/s | No. of Hours | Hourly Rate | Amount (PhP) |
| Equipment | | | | | |
| B.1 | a. Bar Cutter (25 mm Maximum Rebar Ø (Grade 40), Single Phase | 1 | 0.50 | | - |
| | b. Bar Bender (25mm Maximum Rebar Ø), Three Phase | 1 | 0.50 | | - |
| | Minor Tools (10% of Labor Cost) | | | | - |
| | Sub - Total for B.1 | | | | - |
| C.1 | Total (A.1 + B.1) | | | | - |
| D.1 | Output per hour | | | | 129.09 |
| E.1 | Direct Unit Cost (C.1 ÷ D.1) | | | | - |
| | Name and Specification | Unit | Quantity | Unit Cost | Amount (PhP) |
| Materials | | | | | |
| F.1 | a. Deformed Reinforcing Steel Bar | kg. | 1.00 | | - |
| | b. #16 Galvanized Iron Wire | kg. | 0.015 | | - |
| | Consumables (5% of Material Cost) | | | | - |
| | Sub - Total for F.1 | | | | - |
| G.1 | Direct Unit Cost (E.1 + F.1) | | | | - |
| H.1 | Overhead, Contingencies & Miscellaneous (OCM) (5% of G.1) | | | 5% | - |
| I.1 | Engineering Overh (5% of G.1) | | | 5% | - |
| J.1 | Contractor's Profit (CP) - (8% of G.1) | | | 8% | - |
| K.1 | Value Added Tax (VAT) - ((G.1+H.1+J.1+I.1)*7%) | | | 7% | - |
| L.1 | Total Unit Cost - (G.1+(H.1+J.1+I.1+K.1) | | | | - |

| | | | | | | |
|------------------------|--|--|--------------------|-------------------|---------------------|---|
| Item No. / Description | : II.E - Conduits, Boxes & Fittings (Conduit Works/Conduit Rough-in) | | | | | |
| Unit of Measurement | : L.S | | | | | |
| Output per hour | : 1.00 | | | | | |
| | Designation | No. of Person/s | No. of Days | Daily Rate | Amount (PhP) | |
| A.1 | Labor | | | | | |
| | a. Construction Foreman | 1 | 5.00 | | - | |
| | b. Skilled Labor | 1 | 5.00 | | - | |
| | c. Unskilled Labor | 2 | 5.00 | | - | |
| | Sub - Total for A.1 | | | | - | |
| | Name and Capacity | No. of Unit/s | No. of Days | Daily Rate | Amount (PhP) | |
| B.1 | Equipment | | | | | |
| | Minor Tools (10% of Labor Cost) | | | | - | |
| | Sub - Total for B.1 | | | | - | |
| C.1 | Total (A.1 + B.1) | | | | | |
| D.1 | Output per hour | | | | | |
| E.1 | Direct Unit Cost (C.1 ÷ D.1) | | | | | |
| | Name and Specification | Unit | Quantity | Unit Cost | Amount (PhP) | |
| F.1 | Materials | | | | | |
| | 78 mmØ IMC PIPE x 10' | LENGTH | 37.00 | | - | |
| | 53 mmØ EMT PIPE x 10' | LENGTH | 10.00 | | - | |
| | 53 mmØ ELBOW x 10' | PCS | 4.00 | | - | |
| | 53 mmØ EMT COUPLING | PCS | 15.00 | | - | |
| | 53 mmØ EMT CONNECTOR | PCS | 4.00 | | - | |
| | 35 mmØ EMT PIPE x 10' | LENGTH | 4.00 | | - | |
| | 35 mmØ EMT ELBOW x 10' | PCS | 6.00 | | - | |
| | 35 mmØ EMT COUPLING | PCS | 40.00 | | - | |
| | 35 mmØ EMT CONNECTOR | PCS | 4.00 | | - | |
| | 78 mmØ RSC ENTRANCE CAP | PCS | 2.00 | | - | |
| | 78 mmØ RSC COUPLING | PCS | 40.00 | | - | |
| | 78 mmØ RSC ELBOW 90° | PCS | 18.00 | | - | |
| | 78 mmØ RSC CONNECTOR | PCS | 46.00 | | - | |
| | SECONDARY RACK, 4 POLE W/ SPOOL HEAVY DUT | PCS | 1.00 | | - | |
| | ELECTRICAL TAPE 3M BIG | PCS | 10.00 | | - | |
| | RUBBER TAPE 3M BIG | PCS | 4.00 | | - | |
| | 3" U-BOLT W/ NUT & WASHER | PCS | 100.00 | | - | |
| | 3" CLIP | PCS | 100.00 | | - | |
| | 2" CLIP | PCS | 40.00 | | - | |
| | TERMINAL LUGS CRIMP TYPE 30mm2 | PCS | 12.00 | | - | |
| | TERMINAL LUGS CRIMP TYPE 60mm2 | PCS | 4.00 | | - | |
| | TERMINAL LUGS CRIMP TYPE 80mm2 | PCS | 6.00 | | - | |
| | TERMINAL LUGS CRIMP TYPE 150mm2 | PCS | 18.00 | | - | |
| | EXPANSION BOLT W/ NUT & LOCK WASHER 3/4 | PCS | 100.00 | | - | |
| | METAL PULL BOX 12" x 12" x 6" with COVER G# 16 | PCS | 15.00 | | - | |
| | 2"x2"x6m ANGLE BAR | LENGTH | 15.00 | | - | |
| | Consumables (10% of total material cost) | | | | - | |
| | Sub - Total for F.1 | | | | - | |
| | G.1 | Direct Unit Cost (E.1 + F.1) | | | | |
| | H.1 | Overhead, Contingencies & Miscellaneous (OCM) (5% of G.1) | | | 5% | - |
| | I.1 | Engineering Overh (5% of G.1) | | | 5% | - |
| J.1 | Contractor's Profit (CP) - (8% of G.1) | | | 8% | - | |
| K.1 | Value Added Tax (VAT) - ((G.1+H.1+J.1+I.1)*7%) | | | 7% | - | |
| L.1 | Total Unit Cost - (G.1+(H.1+J.1+I.1+K.1)) | | | | | |

| | | | | | |
|---|--|------------------------|--------------------|-------------------|---------------------|
| Item No. / Description : II.F - Wires and Wiring Devices | | | | | |
| Unit of Measurement : L.S | | | | | |
| Output per hour : 1.00 | | | | | |
| | Designation | No. of Person/s | No. of Days | Daily Rate | Amount (PhP) |
| A.1 | Labor | | | | |
| | a. Construction Foreman | 1 | 25.00 | | - |
| | b. Skilled Labor | 2 | 25.00 | | - |
| | c. Unskilled Labor | 4 | 25.00 | | - |
| | Sub - Total for A.1 | | | | |
| | Name and Capacity | No. of Unit/s | No. of Days | Daily Rate | Amount (PhP) |
| B.1 | Equipment | | | | |
| | Minor Tools (10% of Labor Cost) | | | | - |
| | | | | | |
| | Sub - Total for B.1 | | | | |
| C.1 | Total (A.1 + B.1) | | | | - |
| D.1 | Output per hour | | | | 1.00 |
| E.1 | Direct Unit Cost (C.1 ÷ D.1) | | | | - |
| | Name and Specification | Unit | Quantity | Unit Cost | Amount (PhP) |
| F.1 | Materials | | | | |
| | 150 mm ² THW | MTS | 660.00 | | - |
| | 80 mm ² THHN | MTS | 75.00 | | - |
| | 30 mm ² THHN | MTS | 50.00 | | - |
| | 14mm ² THHN | MTS | 10.00 | | - |
| | 8.0 mm ² THHN | MTS | 25.00 | | - |
| | 5.5 mm ² THHN | ROLL | 1.00 | | - |
| | 3.5 mm ² THHN | ROLL | 1.00 | | - |
| | 60 mm ² TW | MTS | 110.00 | | - |
| | Consumables (10% of total material cost) | | | | - |
| | Sub - Total for F.1 | | | | |
| G.1 | Direct Unit Cost (E.1 + F.1) | | | | - |
| H.1 | Overhead, Contingencies & Miscellaneous (OCM) (5% of G.1) | | | 5% | - |
| I.1 | Engineering Overh (5% of G.1) | | | 5% | - |
| J.1 | Contractor's Profit (CP) - (8% of G.1) | | | 8% | - |
| K.1 | Value Added Tax (VAT) - ((G.1+H.1+J.1+I.1)*7%) | | | 7% | - |
| L.1 | Total Unit Cost - (G.1+(H.1+J.1+I.1+J.1+K.1) | | | | - |

| | | | | | |
|----------------------------|--|------------------------|--------------------|-------------------|---------------------|
| Item No. / Description | : II.G - Panelboard with Main & Branch Breakers | | | | |
| Unit of Measurement | : L.S | | | | |
| Output per hour | : 1.00 | | | | |
| A.1 | Designation | No. of Person/s | No. of Days | Daily Rate | Amount (PhP) |
| | Labor | | | | |
| | a. Construction Foreman | 1 | 10.00 | | - |
| | b. Skilled Labor | 1 | 10.00 | | - |
| | c. Unskilled Labor | 3 | 10.00 | | - |
| Sub - Total for A.1 | | | | | - |
| B.1 | Name and Capacity | No. of Unit/s | No. of Days | Daily Rate | Amount (PhP) |
| | Equipment | | | | |
| | Minor Tools (10% of Labor Cost) | | | | - |
| | Sub - Total for B.1 | | | | |
| C.1 | Total (A.1 + B.1) | | | | - |
| D.1 | Output per hour | | | | 1.00 |
| E.1 | Direct Unit Cost (C.1 ÷ D.1) | | | | - |
| F.1 | Name and Specification | Unit | Quantity | Unit Cost | Amount (PhP) |
| | Materials | | | | |
| | MTS - W/ PILOT LIGHT & MECHANICAL INTERLOCK 2 x 600 AT / 650AF , 3P, 230V , BOLT-ON , CIRCUIT BREAKER | SET | 1.00 | | - |
| | NEMA 3R W/ 600 AT / 600 AF , 3P, 230 V, BOLT ON, CIRCUIT BREAKER | SET | 1.00 | | - |
| | DP3 - 175 AT / 175 AF , 3P, 230 V, BOLT ON, CIRCUIT BREAKER BRANCHES - 6 2 x 100 AT / 100AF , 3P, 230V , BOLT-ON , CIRCUIT BREAKER 1 x 60 AT / 60AF , 3P, 230V , BOLT-ON , CIRCUIT BREAKER 2 x 30 AT / 50AF , 3P, 230V , BOLT-ON , CIRCUIT BREAKER | SET | 1.00 | | - |
| | PB3 & PB4 - 100 AT / 100 AF , 3P, 230 V, BOLT ON, CIRCUIT BREAKER BRANCHES - 12 6 x 30 AT / 50AF , 2P, 230V , BOLT-ON , CIRCUIT BREAKER 6 x 20 AT / 50AF , 2P, 230V , BOLT-ON , CIRCUIT BREAKER | SET | 2.00 | | - |
| | PBB3 - 100 AT / 100 AF , 3P, 230 V, BOLT ON, CIRCUIT BREAKER BRANCHES - 10 4 x 30 AT / 50AF , 2P, 230V , BOLT-ON , CIRCUIT BREAKER 6 x 20 AT / 50AF , 2P, 230V , BOLT-ON , CIRCUIT BREAKER | SET | 1.00 | | - |
| Sub - Total for F.1 | | | | | - |
| G.1 | Direct Unit Cost (E.1 + F.1) | | | | - |
| H.1 | Overhead, Contingencies & Miscellaneous (OCM) (5% of G.1) | | | 5% | - |
| I.1 | Engineering Overh(5% of G.1) | | | 5% | - |
| J.1 | Contractor's Profit (CP) - (8% of G.1) | | | 8% | - |
| K.1 | Value Added Tax (VAT) - ((G.1+H.1+J.1+I.1)*7%) | | | 7% | - |
| L.1 | Total Unit Cost - (G.1+H.1+J.1+I.1+J.1+K.1) | | | | - |

Section IX. Checklist of Technical and Financial Documents

Checklist of Technical and Financial Documents

I. TECHNICAL COMPONENT ENVELOPE

Class "A" Documents

Legal Documents

- (a) Valid PhilGEPS Registration Certificate (Platinum Membership) (all pages);
or
- (b) Registration certificate from Securities and Exchange Commission (SEC), Department of Trade and Industry (DTI) for sole proprietorship, or Cooperative Development Authority (CDA) for cooperatives or its equivalent document;
and
- (c) Mayor's or Business permit issued by the city or municipality where the principal place of business of the prospective bidder is located, or the equivalent document for Exclusive Economic Zones or Areas;
and
- (e) Tax clearance per E.O. No. 398, s. 2005, as finally reviewed and approved by the Bureau of Internal Revenue (BIR).

Technical Documents

- (f) Statement of the prospective bidder of all its ongoing government and private contracts, including contracts awarded but not yet started, if any, whether similar or not similar in nature and complexity to the contract to be bid; **and**
- (g) Statement of the bidder's Single Largest Completed Contract (SLCC) similar to the contract to be bid, except under conditions provided under the rules;
and
- (h) Philippine Contractors Accreditation Board (PCAB) License;
or
Special PCAB License in case of Joint Ventures;
and registration for the type and cost of the contract to be bid; **and**
- (i) Original copy of Bid Security. If in the form of a Surety Bond, submit also a certification issued by the Insurance Commission;
or
Original copy of Notarized Bid Securing Declaration; **and**
- (j) Project Requirements, which shall include the following:
 - a. Organizational chart for the contract to be bid;
 - b. List of contractor's key personnel (*e.g.*, Project Manager, Project Engineer, Electrical Engineer, and Foremen), to be assigned to the contract to be bid, with their complete qualification and experience data;
 - c. List of contractor's major equipment units, which are owned, leased, and/or under purchase agreements, supported by proof of ownership or certification of availability of equipment from the equipment lessor/vendor for the duration of the project, as the case may be;

- d. Affidavit of site inspection;
 - e. Sworn Statement of Compliance with the Drawings and Specifications;
 - f. Statement of Availability of Key Personnel and Equipment; **and**
- (k) Original duly signed Omnibus Sworn Statement (OSS); **and** if applicable, Original Notarized Secretary's Certificate in case of a corporation, partnership, or cooperative; or Original Special Power of Attorney of all members of the joint venture giving full power and authority to its officer to sign the OSS and do acts to represent the Bidder.

Financial Documents

- (l) The prospective bidder's audited financial statements, showing, among others, the prospective bidder's total and current assets and liabilities, stamped "received" by the BIR or its duly accredited and authorized institutions, for the preceding calendar year which should not be earlier than two (2) years from the date of bid submission; **and**
- (m) The prospective bidder's computation of Net Financial Contracting Capacity (NFCC).

Class "B" Documents

- (n) If applicable, duly signed joint venture agreement (JVA) in accordance with RA No. 4566 and its IRR in case the joint venture is already in existence; **or** duly notarized statements from all the potential joint venture partners stating that they will enter into and abide by the provisions of the JVA in the instance that the bid is successful.

II. FINANCIAL COMPONENT ENVELOPE

- (o) Original of duly signed and accomplished Financial Bid Form; **and**

Other documentary requirements under RA No. 9184

- (p) Original of duly signed Bid Prices in the Bill of Quantities; **and**
- (q) Duly accomplished Detailed Estimates Form, including a summary sheet indicating the unit prices of construction materials, labor rates, and equipment rentals used in coming up with the Bid; **and**
- (r) Cash Flow by Quarter.

Section X. Bid Forms

TABLE OF CONTENTS

| | |
|---|----|
| Bid Forms..... | 51 |
| Contract Agreement Form..... | 53 |
| Omnibus Sworn Statement..... | 55 |
| Bid Securing Declaration Form..... | 57 |
| Statement of all ongoing government and private contracts including constructions and contracts awarded but not yet started..... | 58 |
| Statement of Single Largest Completed Contract..... | 60 |
| List of Key Personnel Proposed to be Assigned to the Contract..... | 61 |
| List of Equipment, Owned or Leased and/or under Purchase Agreement, Pledged to the Proposed Contract..... | 63 |
| Sworn Statement of Compliance with the Drawings and Specifications..... | 65 |
| Affidavit of Site Inspection..... | 66 |
| Statement of Availability of Key Personnel and Equipment..... | 67 |

Bid Form for the Procurement of Infrastructure Projects

[shall be submitted with the Bid]

BID FORM

Date : _____

Project Identification No. : _____

To: *[name and address of Procuring Entity]*

Having examined the Philippine Bidding Documents (PBDs) including the Supplemental or Bid Bulletin Numbers *[insert numbers]*, the receipt of which is hereby duly acknowledged, we, the undersigned, declare that:

- a. We have no reservation to the PBDs, including the Supplemental or Bid Bulletins, for the Procurement Project: *[insert name of contract]*;
- b. We offer to execute the Works for this Contract in accordance with the PBDs;
- c. The total price of our Bid in words and figures, excluding any discounts offered below is: *[insert information]*;
- d. The discounts offered and the methodology for their application are: *[insert information]*;
- e. The total bid price includes the cost of all taxes, such as, but not limited to: *[specify the applicable taxes, e.g. (i) value added tax (VAT), (ii) income tax, (iii) local taxes, and (iv) other fiscal levies and duties]*, which are itemized herein and reflected in the detailed estimates,
- f. Our Bid shall be valid within the a period stated in the PBDs, and it shall remain binding upon us at any time before the expiration of that period;
- g. If our Bid is accepted, we commit to obtain a Performance Security in the amount of *[insert percentage amount]* percent of the Contract Price for the due performance of the Contract, or a Performance Securing Declaration in lieu of the the allowable forms of Performance Security, subject to the terms and conditions of issued GPPB guidelines¹ for this purpose;
- h. We are not participating, as Bidders, in more than one Bid in this bidding process, other than alternative offers in accordance with the Bidding Documents;
- i. We understand that this Bid, together with your written acceptance thereof included in your notification of award, shall constitute a binding contract between us, until a formal Contract is prepared and executed; and
- j. We understand that you are not bound to accept the Lowest Calculated Bid or any other Bid that you may receive.
- k. We likewise certify/confirm that the undersigned, is the duly authorized

¹ currently based on GPPB Resolution No. 09-2020

representative of the bidder, and granted full power and authority to do, execute and perform any and all acts necessary to participate, submit the bid, and to sign and execute the ensuing contract for the [Name of Project] of the [Name of the Procuring Entity].

- I. We acknowledge that failure to sign each and every page of this Bid Form, including the Bill of Quantities, shall be a ground for the rejection of our bid.

Name: _____

Legal Capacity: _____

Signature: _____

Duly authorized to sign the Bid for and behalf of: _____

Date: _____

Contract Agreement Form for the Procurement of Infrastructure Projects (Revised)

[not required to be submitted with the Bid, but it shall be submitted within ten (10) days after receiving the Notice of Award]

CONTRACT AGREEMENT

THIS AGREEMENT, made this *[insert date]* day of *[insert month]*, *[insert year]* between *[name and address of PROCURING ENTITY]* (hereinafter called the "Entity") and *[name and address of Contractor]* (hereinafter called the "Contractor").

WHEREAS, the Entity is desirous that the Contractor execute *[name and identification number of contract]* (hereinafter called "the Works") and the Entity has accepted the Bid for *[contract price in words and figures in specified currency]* by the Contractor for the execution and completion of such Works and the remedying of any defects therein.

NOW THIS AGREEMENT WITNESSETH AS FOLLOWS:

1. In this Agreement, words and expressions shall have the same meanings as are respectively assigned to them in the Conditions of Contract hereinafter referred to.
2. The following documents as required by the 2016 revised Implementing Rules and Regulations of Republic Act No. 9184 shall be deemed to form and be read and construed as part of this Agreement, *viz.*:
 - a. Philippine Bidding Documents (PBDs);
 - i. Drawings/Plans;
 - ii. Specifications;
 - iii. Bill of Quantities;
 - iv. General and Special Conditions of Contract;
 - v. Supplemental or Bid Bulletins, if any;
 - b. Winning bidder's bid, including the Eligibility requirements, Technical and Financial Proposals, and all other documents or statements submitted;

Bid form, including all the documents/statements contained in the Bidder's bidding envelopes, as annexes, and all other documents submitted (*e.g.*, Bidder's response to request for clarifications on the bid), including corrections to the bid, if any, resulting from the Procuring Entity's bid evaluation;

- c. Performance Security;
- d. Notice of Award of Contract and the Bidder's conforme thereto; and
- e. Other contract documents that may be required by existing laws and/or the Procuring Entity concerned in the PBDs. **Winning bidder agrees that additional contract documents or information prescribed by the GPPB that are subsequently required for submission after the contract execution, such as the Notice to Proceed, Variation Orders, and Warranty Security, shall likewise form part of the Contract.**

3. In consideration for the sum of *[total contract price in words and figures]* or such other sums as may be ascertained, *[Named of the bidder]* agrees to *[state the object of the contract]* in accordance with his/her/its Bid.
4. The *[Name of the procuring entity]* agrees to pay the above-mentioned sum in accordance with the terms of the Bidding.

IN WITNESS whereof the parties thereto have caused this Agreement to be executed the day and year first before written.

[Insert Name and Signature]

[Insert Name and Signature]

[Insert Signatory's Legal Capacity]

[Insert Signatory's Legal Capacity]

for:

for:

[Insert Procuring Entity]

[Insert Name of Supplier]

Acknowledgment

[Format shall be based on the latest Rules on Notarial Practice]

Omnibus Sworn Statement (Revised)

[shall be submitted with the Bid]

REPUBLIC OF THE PHILIPPINES)
CITY/MUNICIPALITY OF _____) S.S.

AFFIDAVIT

I, [Name of Affiant], of legal age, [Civil Status], [Nationality], and residing at [Address of Affiant], after having been duly sworn in accordance with law, do hereby depose and state that:

1. *[Select one, delete the other:]*

[If a sole proprietorship:] I am the sole proprietor or authorized representative of [Name of Bidder] with office address at [address of Bidder];

[If a partnership, corporation, cooperative, or joint venture:] I am the duly authorized and designated representative of [Name of Bidder] with office address at [address of Bidder];

2. *[Select one, delete the other:]*

[If a sole proprietorship:] As the owner and sole proprietor, or authorized representative of [Name of Bidder], I have full power and authority to do, execute and perform any and all acts necessary to participate, submit the bid, and to sign and execute the ensuing contract for [Name of the Project] of the [Name of the Procuring Entity], as shown in the attached duly notarized Special Power of Attorney;

[If a partnership, corporation, cooperative, or joint venture:] I am granted full power and authority to do, execute and perform any and all acts necessary to participate, submit the bid, and to sign and execute the ensuing contract for [Name of the Project] of the [Name of the Procuring Entity], as shown in the attached [state title of attached document showing proof of authorization (e.g., duly notarized Secretary's Certificate, Board/Partnership Resolution, or Special Power of Attorney, whichever is applicable)];

3. [Name of Bidder] is not "blacklisted" or barred from bidding by the Government of the Philippines or any of its agencies, offices, corporations, or Local Government Units, foreign government/foreign or international financing institution whose blacklisting rules have been recognized by the Government Procurement Policy Board, **by itself or by relation, membership, association, affiliation, or controlling interest with another blacklisted person or entity as defined and provided for in the Uniform Guidelines on Blacklisting;**

4. Each of the documents submitted in satisfaction of the bidding requirements is an authentic copy of the original, complete, and all statements and information provided therein are true and correct;

5. [Name of Bidder] is authorizing the Head of the Procuring Entity or its duly authorized representative(s) to verify all the documents submitted;

6. *[Select one, delete the rest:]*

[If a sole proprietorship:] The owner or sole proprietor is not related to the Head of the Procuring Entity, members of the Bids and Awards Committee (BAC), the Technical Working Group, and the BAC Secretariat, the head of the Project Management Office or the end-user unit, and the project consultants by consanguinity or affinity up to the third civil degree;

[If a partnership or cooperative:] None of the officers and members of *[Name of Bidder]* is related to the Head of the Procuring Entity, members of the Bids and Awards Committee (BAC), the Technical Working Group, and the BAC Secretariat, the head of the Project Management Office or the end-user unit, and the project consultants by consanguinity or affinity up to the third civil degree;

[If a corporation or joint venture:] None of the officers, directors, and controlling stockholders of *[Name of Bidder]* is related to the Head of the Procuring Entity, members of the Bids and Awards Committee (BAC), the Technical Working Group, and the BAC Secretariat, the head of the Project Management Office or the end-user unit, and the project consultants by consanguinity or affinity up to the third civil degree;

7. *[Name of Bidder]* complies with existing labor laws and standards; and
8. *[Name of Bidder]* is aware of and has undertaken the responsibilities as a Bidder in compliance with the Philippine Bidding Documents, which includes:
 - a. Carefully examining all of the Bidding Documents;
 - b. Acknowledging all conditions, local or otherwise, affecting the implementation of the Contract;
 - c. Making an estimate of the facilities available and needed for the contract to be bid, if any; and
 - d. Inquiring or securing Supplemental/Bid Bulletin(s) issued for the *[Name of the Project]*.
9. *[Name of Bidder]* did not give or pay directly or indirectly, any commission, amount, fee, or any form of consideration, pecuniary or otherwise, to any person or official, personnel or representative of the government in relation to any procurement project or activity.
10. **In case advance payment was made or given, failure to perform or deliver any of the obligations and undertakings in the contract shall be sufficient grounds to constitute criminal liability for Swindling (Estafa) or the commission of fraud with unfaithfulness or abuse of confidence through misappropriating or converting any payment received by a person or entity under an obligation involving the duty to deliver certain goods or services, to the prejudice of the public and the government of the Philippines pursuant to Article 315 of Act No. 3815 s. 1930, as amended, or the Revised Penal Code.**

IN WITNESS WHEREOF, I have hereunto set my hand this ___ day of ___, 20___ at _____, Philippines.

[Insert NAME OF BIDDER OR ITS AUTHORIZED REPRESENTATIVE]

[Insert signatory's legal capacity]

Affiant

[Jurat]

[Format shall be based on the latest Rules on Notarial Practice]

Bid Securing Declaration Form

[shall be submitted with the Bid if bidder opts to provide this form of bid security]

REPUBLIC OF THE PHILIPPINES)
CITY OF _____) S.S.

BID SECURING DECLARATION **Project Identification No.: *[Insert number]***

To: *[Insert name and address of the Procuring Entity]*

I/We, the undersigned, declare that:

1. I/We understand that, according to your conditions, bids must be supported by a Bid Security, which may be in the form of a Bid Securing Declaration.
2. I/We accept that: (a) I/we will be automatically disqualified from bidding for any procurement contract with any procuring entity for a period of two (2) years upon receipt of your Blacklisting Order; and, (b) I/we will pay the applicable fine provided under Section 6 of the Guidelines on the Use of Bid Securing Declaration, within fifteen (15) days from receipt of the written demand by the procuring entity for the commission of acts resulting to the enforcement of the bid securing declaration under Sections 23.1(b), 34.2, 40.1 and 69.1, except 69.1(f), of the IRR of RA No. 9184; without prejudice to other legal action the government may undertake.
3. I/We understand that this Bid Securing Declaration shall cease to be valid on the following circumstances:
 - a. Upon expiration of the bid validity period, or any extension thereof pursuant to your request;
 - b. I am/we are declared ineligible or post-disqualified upon receipt of your notice to such effect, and (i) I/we failed to timely file a request for reconsideration or (ii) I/we filed a waiver to avail of said right; and
 - c. I am/we are declared the bidder with the Lowest Calculated Responsive Bid, and I/we have furnished the performance security and signed the Contract.

IN WITNESS WHEREOF, I/We have hereunto set my/our hand/s this ____ day of *[month]* *[year]* at *[place of execution]*.

[Insert NAME OF BIDDER OR ITS AUTHORIZED REPRESENTATIVE]

[Insert signatory's legal capacity]

Affiant

[Jurat]

[Format shall be based on the latest Rules on Notarial Practice]

STATEMENT OF ALL ONGOING GOVERNMENT & PRIVATE CONSTRUCTION CONTRACTS INCLUDING CONTRACTS AWARDED BUT NOT YET STARTED

Business Name : _____

Business Address : _____

| Name of Contract/Location Project Cost | a. Owner Name b. Address c. Telephone Nos. | Nature of Work | Contractor's Role | | a. Date Awarded b. Date Started c. Date of Completion | % of Accomplishment | | Value of Outstanding Works |
|---|--|----------------|-------------------|---|---|---------------------|--------|----------------------------|
| | | | Description | % | | Planned | Actual | |
| <u>Government</u> | | | | | | | | |
| | | | | | | | | |
| | | | | | | | | |
| | | | | | | | | |
| | | | | | | | | |
| <u>Private</u> | | | | | | | | |

| | | | | | | | | |
|--|--|--|--|--|--|--|-------------------|--|
| | | | | | | | | |
| | | | | | | | | |
| | | | | | | | | |
| | | | | | | | Total Cost | |

Note: This statement shall be supported by:

1. State all ongoing contracts including those awarded but not yet started (government and private contracts which may be similar or not similar to the project called for bidding) as of:
(The day before the deadline of submission of bids.)
2. If there is no ongoing contract including awarded but not yet started as of the aforementioned period, state none or equivalent term.

Submitted by : _____
(Printed Name & Signature of Authorized Representative)

Designation _____

Date : _____

STATEMENT OF SINGLE LARGEST COMPLETED CONTRACT

Business Name : _____

Business Address : _____

| Name of Contract/Location Project Cost | a. Owner Name b. Address c. Telephone Nos. | Nature of Work | Contractor's Role | | a. Date Awarded b. Date Started c. Date of Completion | % of Accomplishment | | Value of Outstanding Works |
|---|--|----------------|-------------------|---|---|---------------------|--------|----------------------------|
| | | | Description | % | | Planned | Actual | |
| <i>Government</i> | | | | | | | | |
| | | | | | | | | |
| <i>Private</i> | | | | | | | | |
| | | | | | | | | |
| Total Cost | | | | | | | | |

Submitted by : _____
(Printed Name & Signature of Authorized Representative)

Designation _____

Date : _____

LIST OF KEY PERSONNEL PROPOSED TO BE ASSIGNED TO THE CONTRACT (TEMPLATE)

Business Name : _____

Business Address : _____

| | Project Engineer | Electrical Engineer | Foreman |
|------------------------------------|-------------------------|----------------------------|----------------|
| 1. Name | | | |
| 2. Address | | | |
| 3. Date of Birth | | | |
| 4. Employed Since | | | |
| 5. Experience | | | |
| 6. Previous Employment | | | |
| 7. Education | | | |
| 8. PRC License, if applicable | | | |
| 9. Cost of Biggest Project Handled | | | |

| | | | |
|--|--|--|--|
| 10. Years of Experience in the Proposed Position | | | |
|--|--|--|--|

Note: This List must be supported by individual resumes of all personnel and photocopy of PRC Licenses of the Project Manager and Engineers.

Submitted by : _____
(Printed Name & Signature of Authorized Representative)

Designation : _____

Date : _____

LIST OF EQUIPMENT, OWNED OR LEASED AND/OR UNDER PURCHASE AGREEMENT, PLEDGED TO THE PROPOSED CONTRACT

Business Name : _____

Business Address : _____

| Description | Model/Year | Capacity/Performance/Size | Plate No. | Motor No./Body No. | Location | Condition | Proof of Ownership/Lessor/Vendor |
|--------------------|-------------------|----------------------------------|------------------|---------------------------|-----------------|------------------|---|
| A. Owned | | | | | | | |
| 1. | | | | | | | |
| 2. | | | | | | | |
| 3. | | | | | | | |
| B. Leased | | | | | | | |
| 1. | | | | | | | |
| 2. | | | | | | | |

| | | | | | | | |
|-------------------------------------|--|--|--|--|--|--|--|
| 3. | | | | | | | |
| C. Under Purchased Agreement | | | | | | | |
| 1. | | | | | | | |
| 2. | | | | | | | |
| 3. | | | | | | | |

Note: This List must be supported by proof of ownership, lease and/or purchase agreement. For lease and purchase agreement, such proof must include a certification of availability of equipment from the lessor/vendor for the duration of the project.

Submitted by : _____
(Printed Name & Signature of Authorized Representative)

Designation : _____ Date : _____

SWORN STATEMENT OF COMPLIANCE WITH THE DRAWINGS AND SPECIFICATIONS

I, *[Name of Affiant]*, of legal age, *[Civil Status]*, *[Nationality]*, and residing at *[Address of Affiant]*, after having been duly sworn in accordance with law, do hereby depose and state that:

1. That I am the *[Position of the Authorized Representative]* of the *[Name of Bidder]* with office at *[Address of the Bidder]*

2. That in compliance the requirements of DBM Region Office VII , I hereby certify that *[Name of Bidder]* will undertake construction of the Project in accordance with the Drawings and Building Specifications as indicated in the Bidding Documents including Supplemental/Bid Bulletins, if any, for said Project.

3. That I am making this statement as part of the requirement for the Technical Proposal of the *[Name of Bidder]* for the *[Name of Contract/Project]* of the DBM Region Office VII.

IN WITNESS WHEREOF, I have hereunto set my hand this ___ day of ___, 20__ at _____, Philippines.

 Affiant

SUBSCRIBED AND SWORN to before me in the City/Municipality of _____ (indicate also the Province in the case of the Municipality) _____ this _____ day of _____ (month & year) _____ by _____ (name of affiant) _____, who has satisfactorily proven to me his identity through his _____ (ID name and number) _____ valid until _____ (expiry date) _____, that he is the same person who personally signed before me the foregoing Affiant and acknowledged that he executed the same.

 (Notary Public)
 Until _____
 PTR No. _____
 Date _____
 Place _____
 TIN _____
 IBP _____

Doc. No. ;
 Page No. ;
 Book No. ;
 Series of 20__.

AFFIDAVIT OF SITE INSPECTION

I, *[Name of Affiant]*, of legal age, *[Civil Status]*, *[Nationality]*, and residing at *[Address of Affiant]*, after having been duly sworn in accordance with law, do hereby depose and state that:

1. That I am the *[Position of the Authorized Representative]* of the *[Name of Bidder]* with office at *[Address of the Bidder]*
2. That I have inspected the site for *[Name of Contract/Project]*. Located at *[Location of the Contract/Project]* on *[Date of Inspection]*.
3. That I am making this statement as part of the requirement for the Technical Proposal of the *[Name of Bidder]* for the *[Name of Contract/Project]* of the Department of Budget and Management Regional Office VII.

IN WITNESS WHEREOF, I have hereunto set my hand this __ day of __, 20__ at _____, Philippines.

Affiant

SUBSCRIBED AND SWORN to before me in the City/Municipality of _____(indicate also the Province in the case of the Municipality)_____ this _____ day of _____ (month & year) _____ by _____(name of affiant) _____, who has satisfactorily proven to me his identity through his ____ (ID name and number)_____ valid until _____(expiry date) _____, that he is the same person who personally signed before me the foregoing Affiant and acknowledged that he executed the same.

(Notary Public)

Until _____
PTR No. _____
Date _____
Place _____
TIN _____
IBP _____

Doc. No. ;
Page No. ;
Book No. ;
Series of 20__.

**STATEMENT OF AVAILABILITY OF KEY PERSONNEL AND
EQUIPMENT**

[Date of Issuance]

*The Chairman
Bids and Awards Committee
Department of Budget and Management*

Dear _____:

In compliance with the requirements of the DBM Bids and Awards Committee for the bidding of the *[Name of the Project]* (“the Project”), we certify that *[Name of the Bidder]* has in its employ key personnel, such as ***Project Manager, Electrical Engineer and Foreman*** who will be engaged for the construction of the said Project.

Further, we likewise certify the availability of equipment that *[Name of the Bidder]* owns, has under lease, and/or has under purchase agreement that may be used for the Project.

Very truly yours,

*[Name of Authorized Representative]
[Position]*

Sealing and Marking of Bid Documents

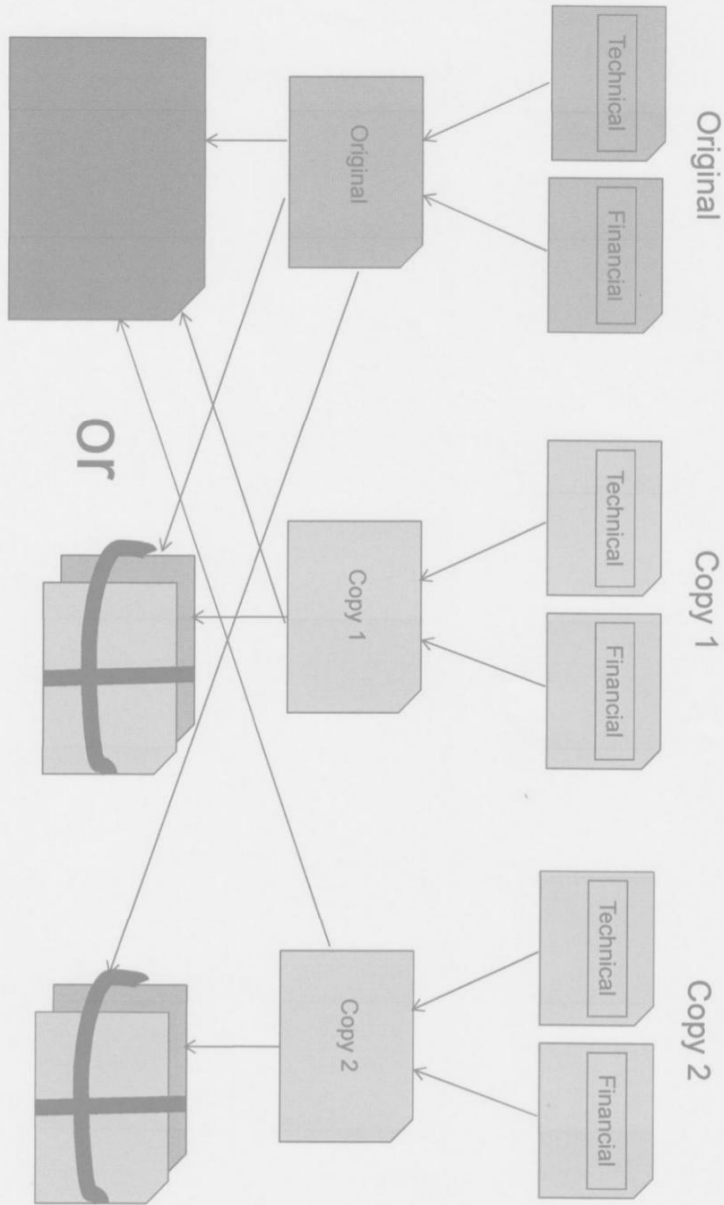

Strict Rules on Marking/Sealing of Bids: Bid envelopes that are not properly sealed and marked, as required in the bidding documents, shall be accepted, provided that the bidder or its duly authorized representative shall acknowledge such condition of the bid as submitted.